



tough.

Live Centers Face Drivers

www.roehm.biz



driven by technology

Table of contents

LIVE CENTERS - FACE DRIVERS

Revolving tailstock centres

MKS - Tip angle 60° 2004

Revolving tailstock centres - for interchangeable inserts

MKS - interchangeable inserts 2016

Interchangeable inserts 2017

Revolving tailstock centres

MKS heavy 2019

Revolving centering tapers

MZK 2022

Accessories MZK 2022

MZK 2023

Dead centres

FKS 2024

Constant face drivers

CoA 2027

Adapter plate CoA 2030

Accessories CoA 2031

CoA Assortments 2035

CoE NEW PRODUCT!!! 2036

Accessories CoE 2037

CoM 2038

Adapter plate CoM 2038

Driving head CoM 2039

Driving discs CoM 2039

Accessories CoM 2040

CoB 2041

Adapter plate CoB 2041

Driving heads CoB 2042

Accessories CoB 2045

Powerful, extremely capable and exceptionally durable. Plus top marks for processing precision. Simply great - through and through!





LIVE CENTERS - FACE DRIVERS

| | | |
|-----------------------------|----------------|------|
| Revolving tailstock centres | | 2004 |
| Revolving centering tapers | | 2022 |
| Dead centres | | 2024 |
| Constant face drivers CoA | | 2027 |
| Constant face drivers CoE | NEW PRODUCT!!! | 2036 |
| Constant face drivers CoM | | 2038 |
| Constant face drivers CoB | | 2041 |

Please note:
The delivery time specified in the catalogue is valid from 01.01.2012

Operation Guide

Workpiece weight max. kg

| MT | 50 | 100 | 150 | 200 | 250 | 300 | 350 | 400 | 500 | 600 | 650 | 700 | 750 | 800 |
|----------|-----------------------------|------------------------------|-------------------------------|------------------------------|--------------------------------|-----------------------------|-------------------------------|------------------------------|--------------------------------|--------------------------|--------------------------|------------------------------|-----------------------------|------------------------------|
| 1 | 604 HM n=7000 RO=0,05 | 601 N n=7000 RO=0,05 | | | | | | | | | | | | |
| | 624 HZ n=7000 RO=0,05 | 604 H n=7000 RO=0,05 | | | | | | | | | | | | |
| | | 604 HVL n=7000 RO=0,01 | | | | | | | | | | | | |
| 2 | 614 n=7000 RO=0,01 | 604 HM n=7000 RO=0,005 | 600-20 n=7000 RO=0,008 | 600 n=7000 RO=0,005 | | | | | | | | | | |
| | | 624 HZ n=7000 RO=0,005 | 604 HVL n=7000 RO=0,005 | 601 N n=7000 RO=0,005 | | | | | | | | | | |
| | | 664 n=12000 RO=0,01 | 604 HMG n=7000 RO=0,005 | 604 H n=7000 RO=0,005 | | | | | | | | | | |
| | | | | 604 HP n=7000 RO=0,003 | | | | | | | | | | |
| | | | | 604 HG n=7000 RO=0,005 | | | | | | | | | | |
| 3 | | 664 n=4000 RO=0,01 | 615 n=8000 RO=0,01 | | 604 HM n=6300 RO=0,005 | 601 N n=6300 RO=0,005 | 600-20 n=7000 RO=0,008 | 600 n=7000 RO=0,005 | 604 HP n=5000 RO=0,003 | | | | | |
| | | | 614 n=5000 RO=0,01 | | 624 HZ n=5000 RO=0,005 | | 604 HMG n=6300 RO=0,005 | 604 H n=5000 RO=0,005 | 604 HG n=5000 RO=0,005 | | | | | |
| | | | | | 652 AC VL n=4000 RO=0,01 | | 604 HVL n=5000 RO=0,005 | | | | | | | |
| | | | | | | | 652 AC n=4000 RO=0,01 | | | | | | | |
| 4 | | | | | 664 n=9000 RO=0,01 | 615 n=7000 RO=0,01 | | 624 HZ n=3800 RO=0,005 | 604 HVL n=3800 RO=0,005 | | | 600-20 n=6300 RO=0,008 | 601-N n=3800 RO=0,005 | 600 n=6300 RO=0,005 |
| | | | | | 614 n=3800 RO=0,01 | | | | 604 HM n=3800 RO=0,005 | | | | | 604 H n=3800 RO=0,005 |
| | | | | | | | | | 604 HMG n=3800 RO=0,005 | | | | | 604 HP n=3800 RO=0,003 |
| | | | | | | | | | 652 AC VL n=3500 RO=0,01 | | | | | 604 HG n=3800 RO=0,003 |
| | | | | | | | | | | | | | | 652 AC n=3500 RO=0,01 |
| 5 | | | | | 664 n=9000 RO=0,01 | | | | | 615 n=5000 RO=0,01 | 614 n=3000 RO=0,01 | | | |
| | | | | | | | | | | | | | | |
| | | | | | | | | | | | | | | |
| 6 | | | | | | | | | | | | | | 614 n=2600 RO=0,015 |
| | | | | | | | | | | | | | | |

Operation Guide

Workpiece weight max. kg

| 1000 | 1100 | 1200 | 1250 | 1400 | 1600 | 1700 | 1800 | 2000 | 2500 | 3000 | 3200 | 3500 | 5000 | MT | | | | | | | | | | | | | | | | | | | | | | | | | | | | | | | | | | | | | | | | | | | | | | | | | | | | | | | | | | | | | | | | | | | | | | | | | | | | | | | | | | | | | | | | | | | | | | | | | | | | | | | | | | | | | | | | | | | | | | | | | | | | | | | | | | | | | | | | | | | | | | | | | | | | | | | | | | | | | | | | | | | | | | | | | | | | | | | | | | | | | | | | | | | | | | | | | | | | | | | | | | | | | | | | | | | | | | | | | | | | | | | | | | | | | | | | | | | | | | | | | | | | | | | | | | | | | | | | | | | | | | | | | | | | | | | | | | | | | | | | | | | | | | | | | | | | | | | | | | | | | | | | | | | | | | | | | | | | | | | | | | | | | | | | | | | | | | | | | | | | | | | | | | | | | | | | | | | | | | | | | | | | | | | | | | | | | | | | | | | | | | | | | | | | | | | | | | | | | | | | | | | | | | | | | | | | | | | | | | | | | | | | | | | | | | | | | | | | | | | | | | | | | | | | | | | | | | | | | | | | | | | | | | | | | | | | | | | | | | | | | | | | | | | | | | | | | | | | | | | | | | | | | | | | | | | | | | | | | | | | | | | | | | | | | | | | | | | | | | | | | | | | | | | | | | | | | | | | | | | | | | | | | | | | | | | | | | | | | | | | | | | | | | | | | | | | | | | | | | | | | | | | | | | | | | | | | | | | | | | | | | | | | | | | | | | | | | | | | | | | | | | | | | | | | | | | | | | | | | | | | | | | | | | | | | | | | | | | | | | | | | | | | | | | | | | | | | | | | | | | | | | | | | | | | | | | | | | | | | | | | | | | | | | | | | | | | | | | | | | | | | | | | | | | | | | | | | | | | | | | | | | | | | | | | | | | | | | | | | | | | |
|---|------|------|------|------|------|------|------|------|------|------|------|------|------|---|--|--|--|--|--|--|--|--|--|--|--|--|------|-------------------------------|--|--|--|--|--|--|--|--|--|--|--|--|------|----------------------------|--|--|--|--|--|--|--|--|--|--|--|--|---------------------------------|--|--|--|--|--|--|--|--|--|--|--|--|------|------------------------|--|--|--|--|--|--|--|--|--|--|--|--|-------------------------------|--|--|--|--|--|--|--|--|--|--|--|--|------|-----------------------------------|--|--|--|--|--|--|--|--|--|--|--|--|------|-------------------------------------|--|--|--|--|--|--|--|--|--|--|--|--|------|---------------------------------|--|--|--|--|--|--|--|--|--|--|--|--|------|-------------------------------|--|--|--|--|--|--|--|--|--|--|--|--|------|---|--|--|--|--|--|--|--|--|--|--|--|--|------|---|--|--|--|--|--|--|--|--|--|--|--|--|------|--------------------------|--|--|--|--|--|--|--|--|--|--|--|--|----------------------------------|--|--|--|--|--|--|--|--|--|--|--|--|-----------------------------------|--|--|--|--|--|--|--|--|--|--|--|--|------|---|--|--|--|--|--|--|--|--|--|--|--|--|------|-----------------------------|--|--|--|--|--|--|--|--|--|--|--|--|----------------------------------|--|--|--|--|--|--|--|--|--|--|--|--|------|---|--|--|--|--|--|--|--|--|--|--|--|--|------|-----------------------------|--|--|--|--|--|--|--|--|--|--|--|--|-------------------------------|--|--|--|--|--|--|--|--|--|--|--|--|------|---|--|--|--|--|--|--|--|--|--|--|--|--|------|-----------------------------|--|--|--|--|--|--|--|--|--|--|--|--|-------------------------------------|--|--|--|--|--|--|--|--|--|--|--|--|------|--------------|--|--|--|--|--|--|--|--|--|--|--|--|------|------------------------------|--|--|--|--|--|--|--|--|--|--|--|--|-------------------------|--|--|--|--|--|--|--|--|--|--|--|--|---|--|--|--|--|--|--|--|--|--|--|--|--|---|--|--|--|--|--|--|--|--|--|--|--|--|--------------------------------------|--|--|--|--|--|--|--|--|--|--|--|--|------|---|--|--|--|--|--|--|--|--|--|--|--|--|---|------------------------------|--|--|--|--|--|--|--|--|--|--|--|--|------------------------------|--|--|--|--|--|--|--|--|--|--|--|--|---|------------------------------|--|--|--|--|--|--|--|--|--|--|--|--|-------------------------------|--|--|--|--|--|--|--|--|--|--|--|--|-------------------------------|--|--|--|--|--|--|--|--|--|--|--|--|----------------------------|--|--|--|--|--|--|--|--|--|--|--|--|---|-----------------------------|--|--|--|--|--|--|--|--|--|--|--|--|--------------------------|--|--|--|--|--|--|--|--|--|--|--|--|-----------------------------|--|--|--|--|--|--|--|--|--|--|--|--|----------------------------|--|--|--|--|--|--|--|--|--|--|--|--|---|-----------------------------|--|--|--|--|--|--|--|--|--|--|--|--|------------------------------|--|--|--|--|--|--|--|--|--|--|--|--|------------------------------|--|--|--|--|--|--|--|--|--|--|--|--|------------------------------|--|--|--|--|--|--|--|--|--|--|--|--|---|------------------------------|--|--|--|--|--|--|--|--|--|--|--|--|------------------------------|--|--|--|--|--|--|--|--|--|--|--|--|-----------------------------|--|--|--|--|--|--|--|--|--|--|--|--|-----------------------------|--|--|--|--|--|--|--|--|--|--|--|--|---|------------------------------|--|--|--|--|--|--|--|--|--|--|--|--|---------------------------------|--|--|--|--|--|--|--|--|--|--|--|--|------------------------------|--|--|--|--|--|--|--|--|--|--|--|--|--------------------------|--|--|--|--|--|--|--|--|--|--|--|--|---|------------------------------|--|--|--|--|--|--|--|--|--|--|--|--|----------------------------|--|--|--|--|--|--|--|--|--|--|--|--|---|----------------------------|--|--|--|--|--|--|--|--|--|--|--|--|----------------------------|--|--|--|--|--|--|--|--|--|--|--|--|---|-----------------------------|--|--|--|--|--|--|--|--|--|--|--|--|
| <table border="1"> <thead> <tr> <th colspan="13"></th> <th>Page</th> </tr> </thead> <tbody> <tr> <td colspan="13">Body ground (Type 601)</td> <td rowspan="2">2006</td> </tr> <tr> <td colspan="13">Type 601 N standard design</td> </tr> <tr> <td colspan="13">Body hardened (Type 604)</td> <td rowspan="2">2007</td> </tr> <tr> <td colspan="13">Type 604 H body ground</td> </tr> <tr> <td colspan="13">Type 604 HP precision version</td> <td>2007</td> </tr> <tr> <td colspan="13">Type 604 HVL extended live centre</td> <td>2008</td> </tr> <tr> <td colspan="13">Type 604 HVLN profiled centre point</td> <td>2008</td> </tr> <tr> <td colspan="13">Type 604 HM with carbide insert</td> <td>2009</td> </tr> <tr> <td colspan="13">Type 604 HG with draw-off nut</td> <td>2009</td> </tr> <tr> <td colspan="13">Type 604 HMG with draw-off nut and carbide insert</td> <td>2010</td> </tr> <tr> <td colspan="13">Small casing diameter (Type 600)</td> <td rowspan="3">2005</td> </tr> <tr> <td colspan="13">Type 600 standard design</td> </tr> <tr> <td colspan="13">Type 600-20 extended live centre</td> </tr> <tr> <td colspan="13">Type 600-20 profiled centre point</td> <td>2006</td> </tr> <tr> <td colspan="13">VDI shank/DIN 69880, live centre spring loaded (Type 645-00)</td> <td rowspan="2">2012</td> </tr> <tr> <td colspan="13">Type 645-00 standard design</td> </tr> <tr> <td colspan="13">Type 645-20 extended live centre</td> <td>2012</td> </tr> <tr> <td colspan="13">High load, high speed (Type 640)</td> <td rowspan="2">2011</td> </tr> <tr> <td colspan="13">Type 640-20 standard design</td> </tr> <tr> <td colspan="13">Type 640-80 with draw-off nut</td> <td>2011</td> </tr> <tr> <td colspan="13">Pressure display, length compensation (Type 652)</td> <td rowspan="2">2013</td> </tr> <tr> <td colspan="13">Type 652 AC standard design</td> </tr> <tr> <td colspan="13">Type 652 AC-VL extended live centre</td> <td>2014</td> </tr> <tr> <td colspan="13">Other</td> <td rowspan="5">2010</td> </tr> <tr> <td colspan="13">Type 624 HZ with centre bore</td> </tr> <tr> <td colspan="13">Type 615 impact damping</td> </tr> <tr> <td colspan="13">Type 663 for especially high speeds, different head-Ø at same size of shank</td> </tr> <tr> <td colspan="13">Type 664 extended NC-centre with carbide insert</td> </tr> <tr> <td colspan="13">Type 614 for interchangeable inserts</td> <td>2016</td> </tr> <tr> <td colspan="13">n= speed max. min⁻¹ RO= Concentricity deviation</td> <td rowspan="2">4</td> </tr> <tr> <td colspan="13">640-20 n=7000 RO=0,005</td> </tr> <tr> <td colspan="13">640-80 n=7000 RO=0,005</td> <td rowspan="4">5</td> </tr> <tr> <td colspan="13">604 HM n=3000 RO=0,005</td> </tr> <tr> <td colspan="13">652 ACVL n=2500 RO=0,01</td> </tr> <tr> <td colspan="13">604 HVL n=3000 RO=0,005</td> </tr> <tr> <td colspan="13">663 n=10000 RO=0,005</td> <td rowspan="4">6</td> </tr> <tr> <td colspan="13">600-20 n=4300 RO=0,01</td> </tr> <tr> <td colspan="13">600 n=4300 RO=0,01</td> </tr> <tr> <td colspan="13">601 N n=3000 RO=0,005</td> </tr> <tr> <td colspan="13">604 H n=3000 R=0,005</td> <td rowspan="4">6</td> </tr> <tr> <td colspan="13">652 AC n=2500 RO=0,01</td> </tr> <tr> <td colspan="13">604 HP n=3000 RO=0,003</td> </tr> <tr> <td colspan="13">604 HG n=3000 RO=0,005</td> </tr> <tr> <td colspan="13">624 HZ n=3000 RO=0,005</td> <td rowspan="4">6</td> </tr> <tr> <td colspan="13">640-20 n=6000 RO=0,005</td> </tr> <tr> <td colspan="13">640-80 n=6000 RO=0,005</td> </tr> <tr> <td colspan="13">624 HZ n=2600 RO=0,01</td> </tr> <tr> <td colspan="13">604 HM n=2600 RO=0,01</td> <td rowspan="4">6</td> </tr> <tr> <td colspan="13">604 HMG n=2600 RO=0,01</td> </tr> <tr> <td colspan="13">652 AC VL n=1800 RO=0,015</td> </tr> <tr> <td colspan="13">640-20 n=4800 RO=0,005</td> </tr> <tr> <td colspan="13">663 n=7000 R=0,005</td> <td rowspan="2">6</td> </tr> <tr> <td colspan="13">640-80 n=4800 RO=0,005</td> </tr> <tr> <td colspan="13">604 H n=3000 RO=0,02</td> <td rowspan="2">6</td> </tr> <tr> <td colspan="13">604 H n=1500 RO=0,01</td> </tr> <tr> <td colspan="13">604 H n=2600 RO=0,01</td> <td rowspan="2">6</td> </tr> <tr> <td colspan="13">604 HG n=2600 RO=0,01</td> </tr> </tbody> </table> | | | | | | | | | | | | | | | | | | | | | | | | | | | Page | Body ground (Type 601) | | | | | | | | | | | | | 2006 | Type 601 N standard design | | | | | | | | | | | | | Body hardened (Type 604) | | | | | | | | | | | | | 2007 | Type 604 H body ground | | | | | | | | | | | | | Type 604 HP precision version | | | | | | | | | | | | | 2007 | Type 604 HVL extended live centre | | | | | | | | | | | | | 2008 | Type 604 HVLN profiled centre point | | | | | | | | | | | | | 2008 | Type 604 HM with carbide insert | | | | | | | | | | | | | 2009 | Type 604 HG with draw-off nut | | | | | | | | | | | | | 2009 | Type 604 HMG with draw-off nut and carbide insert | | | | | | | | | | | | | 2010 | Small casing diameter (Type 600) | | | | | | | | | | | | | 2005 | Type 600 standard design | | | | | | | | | | | | | Type 600-20 extended live centre | | | | | | | | | | | | | Type 600-20 profiled centre point | | | | | | | | | | | | | 2006 | VDI shank/DIN 69880, live centre spring loaded (Type 645-00) | | | | | | | | | | | | | 2012 | Type 645-00 standard design | | | | | | | | | | | | | Type 645-20 extended live centre | | | | | | | | | | | | | 2012 | High load, high speed (Type 640) | | | | | | | | | | | | | 2011 | Type 640-20 standard design | | | | | | | | | | | | | Type 640-80 with draw-off nut | | | | | | | | | | | | | 2011 | Pressure display, length compensation (Type 652) | | | | | | | | | | | | | 2013 | Type 652 AC standard design | | | | | | | | | | | | | Type 652 AC-VL extended live centre | | | | | | | | | | | | | 2014 | Other | | | | | | | | | | | | | 2010 | Type 624 HZ with centre bore | | | | | | | | | | | | | Type 615 impact damping | | | | | | | | | | | | | Type 663 for especially high speeds, different head-Ø at same size of shank | | | | | | | | | | | | | Type 664 extended NC-centre with carbide insert | | | | | | | | | | | | | Type 614 for interchangeable inserts | | | | | | | | | | | | | 2016 | n= speed max. min ⁻¹ RO= Concentricity deviation | | | | | | | | | | | | | 4 | 640-20 n=7000 RO=0,005 | | | | | | | | | | | | | 640-80 n=7000 RO=0,005 | | | | | | | | | | | | | 5 | 604 HM n=3000 RO=0,005 | | | | | | | | | | | | | 652 ACVL n=2500 RO=0,01 | | | | | | | | | | | | | 604 HVL n=3000 RO=0,005 | | | | | | | | | | | | | 663 n=10000 RO=0,005 | | | | | | | | | | | | | 6 | 600-20 n=4300 RO=0,01 | | | | | | | | | | | | | 600 n=4300 RO=0,01 | | | | | | | | | | | | | 601 N n=3000 RO=0,005 | | | | | | | | | | | | | 604 H n=3000 R=0,005 | | | | | | | | | | | | | 6 | 652 AC n=2500 RO=0,01 | | | | | | | | | | | | | 604 HP n=3000 RO=0,003 | | | | | | | | | | | | | 604 HG n=3000 RO=0,005 | | | | | | | | | | | | | 624 HZ n=3000 RO=0,005 | | | | | | | | | | | | | 6 | 640-20 n=6000 RO=0,005 | | | | | | | | | | | | | 640-80 n=6000 RO=0,005 | | | | | | | | | | | | | 624 HZ n=2600 RO=0,01 | | | | | | | | | | | | | 604 HM n=2600 RO=0,01 | | | | | | | | | | | | | 6 | 604 HMG n=2600 RO=0,01 | | | | | | | | | | | | | 652 AC VL n=1800 RO=0,015 | | | | | | | | | | | | | 640-20 n=4800 RO=0,005 | | | | | | | | | | | | | 663 n=7000 R=0,005 | | | | | | | | | | | | | 6 | 640-80 n=4800 RO=0,005 | | | | | | | | | | | | | 604 H n=3000 RO=0,02 | | | | | | | | | | | | | 6 | 604 H n=1500 RO=0,01 | | | | | | | | | | | | | 604 H n=2600 RO=0,01 | | | | | | | | | | | | | 6 | 604 HG n=2600 RO=0,01 | | | | | | | | | | | | |
| | | | | | | | | | | | | | | | | | | | | | | | | | | | Page | | | | | | | | | | | | | | | | | | | | | | | | | | | | | | | | | | | | | | | | | | | | | | | | | | | | | | | | | | | | | | | | | | | | | | | | | | | | | | | | | | | | | | | | | | | | | | | | | | | | | | | | | | | | | | | | | | | | | | | | | | | | | | | | | | | | | | | | | | | | | | | | | | | | | | | | | | | | | | | | | | | | | | | | | | | | | | | | | | | | | | | | | | | | | | | | | | | | | | | | | | | | | | | | | | | | | | | | | | | | | | | | | | | | | | | | | | | | | | | | | | | | | | | | | | | | | | | | | | | | | | | | | | | | | | | | | | | | | | | | | | | | | | | | | | | | | | | | | | | | | | | | | | | | | | | | | | | | | | | | | | | | | | | | | | | | | | | | | | | | | | | | | | | | | | | | | | | | | | | | | | | | | | | | | | | | | | | | | | | | | | | | | | | | | | | | | | | | | | | | | | | | | | | | | | | | | | | | | | | | | | | | | | | | | | | | | | | | | | | | | | | | | | | | | | | | | | | | | | | | | | | | | | | | | | | | | | | | | | | | | | | | | | | | | | | | | | | | | | | | | | | | | | | | | | | | | | | | | | | | | | | | | | | | | | | | | | | | | | | | | | | | | | | | | | | | | | | | | | | | | | | | | | | | | | | | | | | | | | | | | | | | | | | | | | | | | | | | | | | | | | | | | | | | | | | | | | | | | | | | | | | | | | | | | | | | | | | | | | | | | | | | | | | | | | | | | | | | | | | | | | | | | | | | | | | | | | | | | | | | | | | | | | | | | | | | | | | | | | | | | | | | | | | | | | | | | | | | | | | | | | | | | | | | | | | | | | | | | | | | | | | | | | | | | | | | | | | | | | | | | | | | | | | | |
| | | | | | | | | | | | | | | Body ground (Type 601) | | | | | | | | | | | | | 2006 | | | | | | | | | | | | | | | | | | | | | | | | | | | | | | | | | | | | | | | | | | | | | | | | | | | | | | | | | | | | | | | | | | | | | | | | | | | | | | | | | | | | | | | | | | | | | | | | | | | | | | | | | | | | | | | | | | | | | | | | | | | | | | | | | | | | | | | | | | | | | | | | | | | | | | | | | | | | | | | | | | | | | | | | | | | | | | | | | | | | | | | | | | | | | | | | | | | | | | | | | | | | | | | | | | | | | | | | | | | | | | | | | | | | | | | | | | | | | | | | | | | | | | | | | | | | | | | | | | | | | | | | | | | | | | | | | | | | | | | | | | | | | | | | | | | | | | | | | | | | | | | | | | | | | | | | | | | | | | | | | | | | | | | | | | | | | | | | | | | | | | | | | | | | | | | | | | | | | | | | | | | | | | | | | | | | | | | | | | | | | | | | | | | | | | | | | | | | | | | | | | | | | | | | | | | | | | | | | | | | | | | | | | | | | | | | | | | | | | | | | | | | | | | | | | | | | | | | | | | | | | | | | | | | | | | | | | | | | | | | | | | | | | | | | | | | | | | | | | | | | | | | | | | | | | | | | | | | | | | | | | | | | | | | | | | | | | | | | | | | | | | | | | | | | | | | | | | | | | | | | | | | | | | | | | | | | | | | | | | | | | | | | | | | | | | | | | | | | | | | | | | | | | | | | | | | | | | | | | | | | | | | | | | | | | | | | | | | | | | | | | | | | | | | | | | | | | | | | | | | | | | | | | | | | | | | | | | | | | | | | | | | | | | | | | | | | | | | | | | | | | | | | | | | | | | | | | | | | | | | | | | | | | | | | | | | | | | | | | | | | | | | | | | | | | | | | | | | | | | | | | | | | | | | |
| | | | | | | | | | | | | | | Type 601 N standard design | | | | | | | | | | | | | | | | | | | | | | | | | | | | | | | | | | | | | | | | | | | | | | | | | | | | | | | | | | | | | | | | | | | | | | | | | | | | | | | | | | | | | | | | | | | | | | | | | | | | | | | | | | | | | | | | | | | | | | | | | | | | | | | | | | | | | | | | | | | | | | | | | | | | | | | | | | | | | | | | | | | | | | | | | | | | | | | | | | | | | | | | | | | | | | | | | | | | | | | | | | | | | | | | | | | | | | | | | | | | | | | | | | | | | | | | | | | | | | | | | | | | | | | | | | | | | | | | | | | | | | | | | | | | | | | | | | | | | | | | | | | | | | | | | | | | | | | | | | | | | | | | | | | | | | | | | | | | | | | | | | | | | | | | | | | | | | | | | | | | | | | | | | | | | | | | | | | | | | | | | | | | | | | | | | | | | | | | | | | | | | | | | | | | | | | | | | | | | | | | | | | | | | | | | | | | | | | | | | | | | | | | | | | | | | | | | | | | | | | | | | | | | | | | | | | | | | | | | | | | | | | | | | | | | | | | | | | | | | | | | | | | | | | | | | | | | | | | | | | | | | | | | | | | | | | | | | | | | | | | | | | | | | | | | | | | | | | | | | | | | | | | | | | | | | | | | | | | | | | | | | | | | | | | | | | | | | | | | | | | | | | | | | | | | | | | | | | | | | | | | | | | | | | | | | | | | | | | | | | | | | | | | | | | | | | | | | | | | | | | | | | | | | | | | | | | | | | | | | | | | | | | | | | | | | | | | | | | | | | | | | | | | | | | | | | | | | | | | | | | | | | | | | | | | | | | | | | | | | | | | | | | | | | | | | | | | | | | | | | | | | | | | | | | | | | | | | | | | | | | | | | | | | | | | | | | | | | | | | | | | |
| | | | | | | | | | | | | | | Body hardened (Type 604) | | | | | | | | | | | | | 2007 | | | | | | | | | | | | | | | | | | | | | | | | | | | | | | | | | | | | | | | | | | | | | | | | | | | | | | | | | | | | | | | | | | | | | | | | | | | | | | | | | | | | | | | | | | | | | | | | | | | | | | | | | | | | | | | | | | | | | | | | | | | | | | | | | | | | | | | | | | | | | | | | | | | | | | | | | | | | | | | | | | | | | | | | | | | | | | | | | | | | | | | | | | | | | | | | | | | | | | | | | | | | | | | | | | | | | | | | | | | | | | | | | | | | | | | | | | | | | | | | | | | | | | | | | | | | | | | | | | | | | | | | | | | | | | | | | | | | | | | | | | | | | | | | | | | | | | | | | | | | | | | | | | | | | | | | | | | | | | | | | | | | | | | | | | | | | | | | | | | | | | | | | | | | | | | | | | | | | | | | | | | | | | | | | | | | | | | | | | | | | | | | | | | | | | | | | | | | | | | | | | | | | | | | | | | | | | | | | | | | | | | | | | | | | | | | | | | | | | | | | | | | | | | | | | | | | | | | | | | | | | | | | | | | | | | | | | | | | | | | | | | | | | | | | | | | | | | | | | | | | | | | | | | | | | | | | | | | | | | | | | | | | | | | | | | | | | | | | | | | | | | | | | | | | | | | | | | | | | | | | | | | | | | | | | | | | | | | | | | | | | | | | | | | | | | | | | | | | | | | | | | | | | | | | | | | | | | | | | | | | | | | | | | | | | | | | | | | | | | | | | | | | | | | | | | | | | | | | | | | | | | | | | | | | | | | | | | | | | | | | | | | | | | | | | | | | | | | | | | | | | | | | | | | | | | | | | | | | | | | | | | | | | | | | | | | | | | | | | | | | | | | | | | | | | | | | | | | | | | | | | | | | | | | |
| | | | | | | | | | | | | | | Type 604 H body ground | | | | | | | | | | | | | | | | | | | | | | | | | | | | | | | | | | | | | | | | | | | | | | | | | | | | | | | | | | | | | | | | | | | | | | | | | | | | | | | | | | | | | | | | | | | | | | | | | | | | | | | | | | | | | | | | | | | | | | | | | | | | | | | | | | | | | | | | | | | | | | | | | | | | | | | | | | | | | | | | | | | | | | | | | | | | | | | | | | | | | | | | | | | | | | | | | | | | | | | | | | | | | | | | | | | | | | | | | | | | | | | | | | | | | | | | | | | | | | | | | | | | | | | | | | | | | | | | | | | | | | | | | | | | | | | | | | | | | | | | | | | | | | | | | | | | | | | | | | | | | | | | | | | | | | | | | | | | | | | | | | | | | | | | | | | | | | | | | | | | | | | | | | | | | | | | | | | | | | | | | | | | | | | | | | | | | | | | | | | | | | | | | | | | | | | | | | | | | | | | | | | | | | | | | | | | | | | | | | | | | | | | | | | | | | | | | | | | | | | | | | | | | | | | | | | | | | | | | | | | | | | | | | | | | | | | | | | | | | | | | | | | | | | | | | | | | | | | | | | | | | | | | | | | | | | | | | | | | | | | | | | | | | | | | | | | | | | | | | | | | | | | | | | | | | | | | | | | | | | | | | | | | | | | | | | | | | | | | | | | | | | | | | | | | | | | | | | | | | | | | | | | | | | | | | | | | | | | | | | | | | | | | | | | | | | | | | | | | | | | | | | | | | | | | | | | | | | | | | | | | | | | | | | | | | | | | | | | | | | | | | | | | | | | | | | | | | | | | | | | | | | | | | | | | | | | | | | | | | | | | | | | | | | | | | | | | | | | | | | | | | | | | | | | | | | | | | | | | | | | | | | | | | | | | | | | | | | | | | | | | |
| | | | | | | | | | | | | | | Type 604 HP precision version | | | | | | | | | | | | | 2007 | | | | | | | | | | | | | | | | | | | | | | | | | | | | | | | | | | | | | | | | | | | | | | | | | | | | | | | | | | | | | | | | | | | | | | | | | | | | | | | | | | | | | | | | | | | | | | | | | | | | | | | | | | | | | | | | | | | | | | | | | | | | | | | | | | | | | | | | | | | | | | | | | | | | | | | | | | | | | | | | | | | | | | | | | | | | | | | | | | | | | | | | | | | | | | | | | | | | | | | | | | | | | | | | | | | | | | | | | | | | | | | | | | | | | | | | | | | | | | | | | | | | | | | | | | | | | | | | | | | | | | | | | | | | | | | | | | | | | | | | | | | | | | | | | | | | | | | | | | | | | | | | | | | | | | | | | | | | | | | | | | | | | | | | | | | | | | | | | | | | | | | | | | | | | | | | | | | | | | | | | | | | | | | | | | | | | | | | | | | | | | | | | | | | | | | | | | | | | | | | | | | | | | | | | | | | | | | | | | | | | | | | | | | | | | | | | | | | | | | | | | | | | | | | | | | | | | | | | | | | | | | | | | | | | | | | | | | | | | | | | | | | | | | | | | | | | | | | | | | | | | | | | | | | | | | | | | | | | | | | | | | | | | | | | | | | | | | | | | | | | | | | | | | | | | | | | | | | | | | | | | | | | | | | | | | | | | | | | | | | | | | | | | | | | | | | | | | | | | | | | | | | | | | | | | | | | | | | | | | | | | | | | | | | | | | | | | | | | | | | | | | | | | | | | | | | | | | | | | | | | | | | | | | | | | | | | | | | | | | | | | | | | | | | | | | | | | | | | | | | | | | | | | | | | | | | | | | | | | | | | | | | | | | | | | | | | | | | | | | | | | | | | | | | | | | | | | | | | | | | | | | | | | | | |
| | | | | | | | | | | | | | | Type 604 HVL extended live centre | | | | | | | | | | | | | 2008 | | | | | | | | | | | | | | | | | | | | | | | | | | | | | | | | | | | | | | | | | | | | | | | | | | | | | | | | | | | | | | | | | | | | | | | | | | | | | | | | | | | | | | | | | | | | | | | | | | | | | | | | | | | | | | | | | | | | | | | | | | | | | | | | | | | | | | | | | | | | | | | | | | | | | | | | | | | | | | | | | | | | | | | | | | | | | | | | | | | | | | | | | | | | | | | | | | | | | | | | | | | | | | | | | | | | | | | | | | | | | | | | | | | | | | | | | | | | | | | | | | | | | | | | | | | | | | | | | | | | | | | | | | | | | | | | | | | | | | | | | | | | | | | | | | | | | | | | | | | | | | | | | | | | | | | | | | | | | | | | | | | | | | | | | | | | | | | | | | | | | | | | | | | | | | | | | | | | | | | | | | | | | | | | | | | | | | | | | | | | | | | | | | | | | | | | | | | | | | | | | | | | | | | | | | | | | | | | | | | | | | | | | | | | | | | | | | | | | | | | | | | | | | | | | | | | | | | | | | | | | | | | | | | | | | | | | | | | | | | | | | | | | | | | | | | | | | | | | | | | | | | | | | | | | | | | | | | | | | | | | | | | | | | | | | | | | | | | | | | | | | | | | | | | | | | | | | | | | | | | | | | | | | | | | | | | | | | | | | | | | | | | | | | | | | | | | | | | | | | | | | | | | | | | | | | | | | | | | | | | | | | | | | | | | | | | | | | | | | | | | | | | | | | | | | | | | | | | | | | | | | | | | | | | | | | | | | | | | | | | | | | | | | | | | | | | | | | | | | | | | | | | | | | | | | | | | | | | | | | | | | | | | | | | | | | | | | | | | | | | | | | | | | | | | | | | | | | | | | | | | | | | | | | | |
| | | | | | | | | | | | | | | Type 604 HVLN profiled centre point | | | | | | | | | | | | | 2008 | | | | | | | | | | | | | | | | | | | | | | | | | | | | | | | | | | | | | | | | | | | | | | | | | | | | | | | | | | | | | | | | | | | | | | | | | | | | | | | | | | | | | | | | | | | | | | | | | | | | | | | | | | | | | | | | | | | | | | | | | | | | | | | | | | | | | | | | | | | | | | | | | | | | | | | | | | | | | | | | | | | | | | | | | | | | | | | | | | | | | | | | | | | | | | | | | | | | | | | | | | | | | | | | | | | | | | | | | | | | | | | | | | | | | | | | | | | | | | | | | | | | | | | | | | | | | | | | | | | | | | | | | | | | | | | | | | | | | | | | | | | | | | | | | | | | | | | | | | | | | | | | | | | | | | | | | | | | | | | | | | | | | | | | | | | | | | | | | | | | | | | | | | | | | | | | | | | | | | | | | | | | | | | | | | | | | | | | | | | | | | | | | | | | | | | | | | | | | | | | | | | | | | | | | | | | | | | | | | | | | | | | | | | | | | | | | | | | | | | | | | | | | | | | | | | | | | | | | | | | | | | | | | | | | | | | | | | | | | | | | | | | | | | | | | | | | | | | | | | | | | | | | | | | | | | | | | | | | | | | | | | | | | | | | | | | | | | | | | | | | | | | | | | | | | | | | | | | | | | | | | | | | | | | | | | | | | | | | | | | | | | | | | | | | | | | | | | | | | | | | | | | | | | | | | | | | | | | | | | | | | | | | | | | | | | | | | | | | | | | | | | | | | | | | | | | | | | | | | | | | | | | | | | | | | | | | | | | | | | | | | | | | | | | | | | | | | | | | | | | | | | | | | | | | | | | | | | | | | | | | | | | | | | | | | | | | | | | | | | | | | | | | | | | | | | | | | | | | | | | | | | | | | | | |
| | | | | | | | | | | | | | | Type 604 HM with carbide insert | | | | | | | | | | | | | 2009 | | | | | | | | | | | | | | | | | | | | | | | | | | | | | | | | | | | | | | | | | | | | | | | | | | | | | | | | | | | | | | | | | | | | | | | | | | | | | | | | | | | | | | | | | | | | | | | | | | | | | | | | | | | | | | | | | | | | | | | | | | | | | | | | | | | | | | | | | | | | | | | | | | | | | | | | | | | | | | | | | | | | | | | | | | | | | | | | | | | | | | | | | | | | | | | | | | | | | | | | | | | | | | | | | | | | | | | | | | | | | | | | | | | | | | | | | | | | | | | | | | | | | | | | | | | | | | | | | | | | | | | | | | | | | | | | | | | | | | | | | | | | | | | | | | | | | | | | | | | | | | | | | | | | | | | | | | | | | | | | | | | | | | | | | | | | | | | | | | | | | | | | | | | | | | | | | | | | | | | | | | | | | | | | | | | | | | | | | | | | | | | | | | | | | | | | | | | | | | | | | | | | | | | | | | | | | | | | | | | | | | | | | | | | | | | | | | | | | | | | | | | | | | | | | | | | | | | | | | | | | | | | | | | | | | | | | | | | | | | | | | | | | | | | | | | | | | | | | | | | | | | | | | | | | | | | | | | | | | | | | | | | | | | | | | | | | | | | | | | | | | | | | | | | | | | | | | | | | | | | | | | | | | | | | | | | | | | | | | | | | | | | | | | | | | | | | | | | | | | | | | | | | | | | | | | | | | | | | | | | | | | | | | | | | | | | | | | | | | | | | | | | | | | | | | | | | | | | | | | | | | | | | | | | | | | | | | | | | | | | | | | | | | | | | | | | | | | | | | | | | | | | | | | | | | | | | | | | | | | | | | | | | | | | | | | | | | | | | | | | | | | | | | | | | | | | | | | | | | | | | | | | | | | | |
| | | | | | | | | | | | | | | Type 604 HG with draw-off nut | | | | | | | | | | | | | 2009 | | | | | | | | | | | | | | | | | | | | | | | | | | | | | | | | | | | | | | | | | | | | | | | | | | | | | | | | | | | | | | | | | | | | | | | | | | | | | | | | | | | | | | | | | | | | | | | | | | | | | | | | | | | | | | | | | | | | | | | | | | | | | | | | | | | | | | | | | | | | | | | | | | | | | | | | | | | | | | | | | | | | | | | | | | | | | | | | | | | | | | | | | | | | | | | | | | | | | | | | | | | | | | | | | | | | | | | | | | | | | | | | | | | | | | | | | | | | | | | | | | | | | | | | | | | | | | | | | | | | | | | | | | | | | | | | | | | | | | | | | | | | | | | | | | | | | | | | | | | | | | | | | | | | | | | | | | | | | | | | | | | | | | | | | | | | | | | | | | | | | | | | | | | | | | | | | | | | | | | | | | | | | | | | | | | | | | | | | | | | | | | | | | | | | | | | | | | | | | | | | | | | | | | | | | | | | | | | | | | | | | | | | | | | | | | | | | | | | | | | | | | | | | | | | | | | | | | | | | | | | | | | | | | | | | | | | | | | | | | | | | | | | | | | | | | | | | | | | | | | | | | | | | | | | | | | | | | | | | | | | | | | | | | | | | | | | | | | | | | | | | | | | | | | | | | | | | | | | | | | | | | | | | | | | | | | | | | | | | | | | | | | | | | | | | | | | | | | | | | | | | | | | | | | | | | | | | | | | | | | | | | | | | | | | | | | | | | | | | | | | | | | | | | | | | | | | | | | | | | | | | | | | | | | | | | | | | | | | | | | | | | | | | | | | | | | | | | | | | | | | | | | | | | | | | | | | | | | | | | | | | | | | | | | | | | | | | | | | | | | | | | | | | | | | | | | | | | | | | | | | | | | | | | | |
| | | | | | | | | | | | | | | Type 604 HMG with draw-off nut and carbide insert | | | | | | | | | | | | | 2010 | | | | | | | | | | | | | | | | | | | | | | | | | | | | | | | | | | | | | | | | | | | | | | | | | | | | | | | | | | | | | | | | | | | | | | | | | | | | | | | | | | | | | | | | | | | | | | | | | | | | | | | | | | | | | | | | | | | | | | | | | | | | | | | | | | | | | | | | | | | | | | | | | | | | | | | | | | | | | | | | | | | | | | | | | | | | | | | | | | | | | | | | | | | | | | | | | | | | | | | | | | | | | | | | | | | | | | | | | | | | | | | | | | | | | | | | | | | | | | | | | | | | | | | | | | | | | | | | | | | | | | | | | | | | | | | | | | | | | | | | | | | | | | | | | | | | | | | | | | | | | | | | | | | | | | | | | | | | | | | | | | | | | | | | | | | | | | | | | | | | | | | | | | | | | | | | | | | | | | | | | | | | | | | | | | | | | | | | | | | | | | | | | | | | | | | | | | | | | | | | | | | | | | | | | | | | | | | | | | | | | | | | | | | | | | | | | | | | | | | | | | | | | | | | | | | | | | | | | | | | | | | | | | | | | | | | | | | | | | | | | | | | | | | | | | | | | | | | | | | | | | | | | | | | | | | | | | | | | | | | | | | | | | | | | | | | | | | | | | | | | | | | | | | | | | | | | | | | | | | | | | | | | | | | | | | | | | | | | | | | | | | | | | | | | | | | | | | | | | | | | | | | | | | | | | | | | | | | | | | | | | | | | | | | | | | | | | | | | | | | | | | | | | | | | | | | | | | | | | | | | | | | | | | | | | | | | | | | | | | | | | | | | | | | | | | | | | | | | | | | | | | | | | | | | | | | | | | | | | | | | | | | | | | | | | | | | | | | | | | | | | | | | | | | | | | | | | | | | | | | | | | | | | | | |
| | | | | | | | | | | | | | | Small casing diameter (Type 600) | | | | | | | | | | | | | 2005 | | | | | | | | | | | | | | | | | | | | | | | | | | | | | | | | | | | | | | | | | | | | | | | | | | | | | | | | | | | | | | | | | | | | | | | | | | | | | | | | | | | | | | | | | | | | | | | | | | | | | | | | | | | | | | | | | | | | | | | | | | | | | | | | | | | | | | | | | | | | | | | | | | | | | | | | | | | | | | | | | | | | | | | | | | | | | | | | | | | | | | | | | | | | | | | | | | | | | | | | | | | | | | | | | | | | | | | | | | | | | | | | | | | | | | | | | | | | | | | | | | | | | | | | | | | | | | | | | | | | | | | | | | | | | | | | | | | | | | | | | | | | | | | | | | | | | | | | | | | | | | | | | | | | | | | | | | | | | | | | | | | | | | | | | | | | | | | | | | | | | | | | | | | | | | | | | | | | | | | | | | | | | | | | | | | | | | | | | | | | | | | | | | | | | | | | | | | | | | | | | | | | | | | | | | | | | | | | | | | | | | | | | | | | | | | | | | | | | | | | | | | | | | | | | | | | | | | | | | | | | | | | | | | | | | | | | | | | | | | | | | | | | | | | | | | | | | | | | | | | | | | | | | | | | | | | | | | | | | | | | | | | | | | | | | | | | | | | | | | | | | | | | | | | | | | | | | | | | | | | | | | | | | | | | | | | | | | | | | | | | | | | | | | | | | | | | | | | | | | | | | | | | | | | | | | | | | | | | | | | | | | | | | | | | | | | | | | | | | | | | | | | | | | | | | | | | | | | | | | | | | | | | | | | | | | | | | | | | | | | | | | | | | | | | | | | | | | | | | | | | | | | | | | | | | | | | | | | | | | | | | | | | | | | | | | | | | | | | | | | | | | | | | | | | | | | | | | | | | | | | | | | | | | | |
| | | | | | | | | | | | | | | Type 600 standard design | | | | | | | | | | | | | | | | | | | | | | | | | | | | | | | | | | | | | | | | | | | | | | | | | | | | | | | | | | | | | | | | | | | | | | | | | | | | | | | | | | | | | | | | | | | | | | | | | | | | | | | | | | | | | | | | | | | | | | | | | | | | | | | | | | | | | | | | | | | | | | | | | | | | | | | | | | | | | | | | | | | | | | | | | | | | | | | | | | | | | | | | | | | | | | | | | | | | | | | | | | | | | | | | | | | | | | | | | | | | | | | | | | | | | | | | | | | | | | | | | | | | | | | | | | | | | | | | | | | | | | | | | | | | | | | | | | | | | | | | | | | | | | | | | | | | | | | | | | | | | | | | | | | | | | | | | | | | | | | | | | | | | | | | | | | | | | | | | | | | | | | | | | | | | | | | | | | | | | | | | | | | | | | | | | | | | | | | | | | | | | | | | | | | | | | | | | | | | | | | | | | | | | | | | | | | | | | | | | | | | | | | | | | | | | | | | | | | | | | | | | | | | | | | | | | | | | | | | | | | | | | | | | | | | | | | | | | | | | | | | | | | | | | | | | | | | | | | | | | | | | | | | | | | | | | | | | | | | | | | | | | | | | | | | | | | | | | | | | | | | | | | | | | | | | | | | | | | | | | | | | | | | | | | | | | | | | | | | | | | | | | | | | | | | | | | | | | | | | | | | | | | | | | | | | | | | | | | | | | | | | | | | | | | | | | | | | | | | | | | | | | | | | | | | | | | | | | | | | | | | | | | | | | | | | | | | | | | | | | | | | | | | | | | | | | | | | | | | | | | | | | | | | | | | | | | | | | | | | | | | | | | | | | | | | | | | | | | | | | | | | | | | | | | | | | | | | | | | | | | | | | | | | | | | | | | | | | | | | | | | |
| | | | | | | | | | | | | | | Type 600-20 extended live centre | | | | | | | | | | | | | | | | | | | | | | | | | | | | | | | | | | | | | | | | | | | | | | | | | | | | | | | | | | | | | | | | | | | | | | | | | | | | | | | | | | | | | | | | | | | | | | | | | | | | | | | | | | | | | | | | | | | | | | | | | | | | | | | | | | | | | | | | | | | | | | | | | | | | | | | | | | | | | | | | | | | | | | | | | | | | | | | | | | | | | | | | | | | | | | | | | | | | | | | | | | | | | | | | | | | | | | | | | | | | | | | | | | | | | | | | | | | | | | | | | | | | | | | | | | | | | | | | | | | | | | | | | | | | | | | | | | | | | | | | | | | | | | | | | | | | | | | | | | | | | | | | | | | | | | | | | | | | | | | | | | | | | | | | | | | | | | | | | | | | | | | | | | | | | | | | | | | | | | | | | | | | | | | | | | | | | | | | | | | | | | | | | | | | | | | | | | | | | | | | | | | | | | | | | | | | | | | | | | | | | | | | | | | | | | | | | | | | | | | | | | | | | | | | | | | | | | | | | | | | | | | | | | | | | | | | | | | | | | | | | | | | | | | | | | | | | | | | | | | | | | | | | | | | | | | | | | | | | | | | | | | | | | | | | | | | | | | | | | | | | | | | | | | | | | | | | | | | | | | | | | | | | | | | | | | | | | | | | | | | | | | | | | | | | | | | | | | | | | | | | | | | | | | | | | | | | | | | | | | | | | | | | | | | | | | | | | | | | | | | | | | | | | | | | | | | | | | | | | | | | | | | | | | | | | | | | | | | | | | | | | | | | | | | | | | | | | | | | | | | | | | | | | | | | | | | | | | | | | | | | | | | | | | | | | | | | | | | | | | | | | | | | | | | | | | | | | | | | | | | | | | | | | | | | | | | | | | | | | | | | |
| | | | | | | | | | | | | | | Type 600-20 profiled centre point | | | | | | | | | | | | | 2006 | | | | | | | | | | | | | | | | | | | | | | | | | | | | | | | | | | | | | | | | | | | | | | | | | | | | | | | | | | | | | | | | | | | | | | | | | | | | | | | | | | | | | | | | | | | | | | | | | | | | | | | | | | | | | | | | | | | | | | | | | | | | | | | | | | | | | | | | | | | | | | | | | | | | | | | | | | | | | | | | | | | | | | | | | | | | | | | | | | | | | | | | | | | | | | | | | | | | | | | | | | | | | | | | | | | | | | | | | | | | | | | | | | | | | | | | | | | | | | | | | | | | | | | | | | | | | | | | | | | | | | | | | | | | | | | | | | | | | | | | | | | | | | | | | | | | | | | | | | | | | | | | | | | | | | | | | | | | | | | | | | | | | | | | | | | | | | | | | | | | | | | | | | | | | | | | | | | | | | | | | | | | | | | | | | | | | | | | | | | | | | | | | | | | | | | | | | | | | | | | | | | | | | | | | | | | | | | | | | | | | | | | | | | | | | | | | | | | | | | | | | | | | | | | | | | | | | | | | | | | | | | | | | | | | | | | | | | | | | | | | | | | | | | | | | | | | | | | | | | | | | | | | | | | | | | | | | | | | | | | | | | | | | | | | | | | | | | | | | | | | | | | | | | | | | | | | | | | | | | | | | | | | | | | | | | | | | | | | | | | | | | | | | | | | | | | | | | | | | | | | | | | | | | | | | | | | | | | | | | | | | | | | | | | | | | | | | | | | | | | | | | | | | | | | | | | | | | | | | | | | | | | | | | | | | | | | | | | | | | | | | | | | | | | | | | | | | | | | | | | | | | | | | | | | | | | | | | | | | | | | | | | | | | | | | | | | | | | | | | | | | | | | | | | | | | | | | | | | | | | | | | | | | | | |
| VDI shank/DIN 69880, live centre spring loaded (Type 645-00) | | | | | | | | | | | | | 2012 | | | | | | | | | | | | | | | | | | | | | | | | | | | | | | | | | | | | | | | | | | | | | | | | | | | | | | | | | | | | | | | | | | | | | | | | | | | | | | | | | | | | | | | | | | | | | | | | | | | | | | | | | | | | | | | | | | | | | | | | | | | | | | | | | | | | | | | | | | | | | | | | | | | | | | | | | | | | | | | | | | | | | | | | | | | | | | | | | | | | | | | | | | | | | | | | | | | | | | | | | | | | | | | | | | | | | | | | | | | | | | | | | | | | | | | | | | | | | | | | | | | | | | | | | | | | | | | | | | | | | | | | | | | | | | | | | | | | | | | | | | | | | | | | | | | | | | | | | | | | | | | | | | | | | | | | | | | | | | | | | | | | | | | | | | | | | | | | | | | | | | | | | | | | | | | | | | | | | | | | | | | | | | | | | | | | | | | | | | | | | | | | | | | | | | | | | | | | | | | | | | | | | | | | | | | | | | | | | | | | | | | | | | | | | | | | | | | | | | | | | | | | | | | | | | | | | | | | | | | | | | | | | | | | | | | | | | | | | | | | | | | | | | | | | | | | | | | | | | | | | | | | | | | | | | | | | | | | | | | | | | | | | | | | | | | | | | | | | | | | | | | | | | | | | | | | | | | | | | | | | | | | | | | | | | | | | | | | | | | | | | | | | | | | | | | | | | | | | | | | | | | | | | | | | | | | | | | | | | | | | | | | | | | | | | | | | | | | | | | | | | | | | | | | | | | | | | | | | | | | | | | | | | | | | | | | | | | | | | | | | | | | | | | | | | | | | | | | | | | | | | | | | | | | | | | | | | | | | | | | | | | | | | | | | | | | | | | | | | | | | | | | | | | | | | | | | | | | | | | | | | | | | | | | | | | | | | | | | | | | | | |
| Type 645-00 standard design | | | | | | | | | | | | | | | | | | | | | | | | | | | | | | | | | | | | | | | | | | | | | | | | | | | | | | | | | | | | | | | | | | | | | | | | | | | | | | | | | | | | | | | | | | | | | | | | | | | | | | | | | | | | | | | | | | | | | | | | | | | | | | | | | | | | | | | | | | | | | | | | | | | | | | | | | | | | | | | | | | | | | | | | | | | | | | | | | | | | | | | | | | | | | | | | | | | | | | | | | | | | | | | | | | | | | | | | | | | | | | | | | | | | | | | | | | | | | | | | | | | | | | | | | | | | | | | | | | | | | | | | | | | | | | | | | | | | | | | | | | | | | | | | | | | | | | | | | | | | | | | | | | | | | | | | | | | | | | | | | | | | | | | | | | | | | | | | | | | | | | | | | | | | | | | | | | | | | | | | | | | | | | | | | | | | | | | | | | | | | | | | | | | | | | | | | | | | | | | | | | | | | | | | | | | | | | | | | | | | | | | | | | | | | | | | | | | | | | | | | | | | | | | | | | | | | | | | | | | | | | | | | | | | | | | | | | | | | | | | | | | | | | | | | | | | | | | | | | | | | | | | | | | | | | | | | | | | | | | | | | | | | | | | | | | | | | | | | | | | | | | | | | | | | | | | | | | | | | | | | | | | | | | | | | | | | | | | | | | | | | | | | | | | | | | | | | | | | | | | | | | | | | | | | | | | | | | | | | | | | | | | | | | | | | | | | | | | | | | | | | | | | | | | | | | | | | | | | | | | | | | | | | | | | | | | | | | | | | | | | | | | | | | | | | | | | | | | | | | | | | | | | | | | | | | | | | | | | | | | | | | | | | | | | | | | | | | | | | | | | | | | | | | | | | | | | | | | | | | | | | | | | | | | | | | | | | | | | | | | | | | | | | | | | | | | | | | |
| Type 645-20 extended live centre | | | | | | | | | | | | | 2012 | | | | | | | | | | | | | | | | | | | | | | | | | | | | | | | | | | | | | | | | | | | | | | | | | | | | | | | | | | | | | | | | | | | | | | | | | | | | | | | | | | | | | | | | | | | | | | | | | | | | | | | | | | | | | | | | | | | | | | | | | | | | | | | | | | | | | | | | | | | | | | | | | | | | | | | | | | | | | | | | | | | | | | | | | | | | | | | | | | | | | | | | | | | | | | | | | | | | | | | | | | | | | | | | | | | | | | | | | | | | | | | | | | | | | | | | | | | | | | | | | | | | | | | | | | | | | | | | | | | | | | | | | | | | | | | | | | | | | | | | | | | | | | | | | | | | | | | | | | | | | | | | | | | | | | | | | | | | | | | | | | | | | | | | | | | | | | | | | | | | | | | | | | | | | | | | | | | | | | | | | | | | | | | | | | | | | | | | | | | | | | | | | | | | | | | | | | | | | | | | | | | | | | | | | | | | | | | | | | | | | | | | | | | | | | | | | | | | | | | | | | | | | | | | | | | | | | | | | | | | | | | | | | | | | | | | | | | | | | | | | | | | | | | | | | | | | | | | | | | | | | | | | | | | | | | | | | | | | | | | | | | | | | | | | | | | | | | | | | | | | | | | | | | | | | | | | | | | | | | | | | | | | | | | | | | | | | | | | | | | | | | | | | | | | | | | | | | | | | | | | | | | | | | | | | | | | | | | | | | | | | | | | | | | | | | | | | | | | | | | | | | | | | | | | | | | | | | | | | | | | | | | | | | | | | | | | | | | | | | | | | | | | | | | | | | | | | | | | | | | | | | | | | | | | | | | | | | | | | | | | | | | | | | | | | | | | | | | | | | | | | | | | | | | | | | | | | | | | | | | | | | | | | | | | | | | | | | | | | | | | | |
| High load, high speed (Type 640) | | | | | | | | | | | | | 2011 | | | | | | | | | | | | | | | | | | | | | | | | | | | | | | | | | | | | | | | | | | | | | | | | | | | | | | | | | | | | | | | | | | | | | | | | | | | | | | | | | | | | | | | | | | | | | | | | | | | | | | | | | | | | | | | | | | | | | | | | | | | | | | | | | | | | | | | | | | | | | | | | | | | | | | | | | | | | | | | | | | | | | | | | | | | | | | | | | | | | | | | | | | | | | | | | | | | | | | | | | | | | | | | | | | | | | | | | | | | | | | | | | | | | | | | | | | | | | | | | | | | | | | | | | | | | | | | | | | | | | | | | | | | | | | | | | | | | | | | | | | | | | | | | | | | | | | | | | | | | | | | | | | | | | | | | | | | | | | | | | | | | | | | | | | | | | | | | | | | | | | | | | | | | | | | | | | | | | | | | | | | | | | | | | | | | | | | | | | | | | | | | | | | | | | | | | | | | | | | | | | | | | | | | | | | | | | | | | | | | | | | | | | | | | | | | | | | | | | | | | | | | | | | | | | | | | | | | | | | | | | | | | | | | | | | | | | | | | | | | | | | | | | | | | | | | | | | | | | | | | | | | | | | | | | | | | | | | | | | | | | | | | | | | | | | | | | | | | | | | | | | | | | | | | | | | | | | | | | | | | | | | | | | | | | | | | | | | | | | | | | | | | | | | | | | | | | | | | | | | | | | | | | | | | | | | | | | | | | | | | | | | | | | | | | | | | | | | | | | | | | | | | | | | | | | | | | | | | | | | | | | | | | | | | | | | | | | | | | | | | | | | | | | | | | | | | | | | | | | | | | | | | | | | | | | | | | | | | | | | | | | | | | | | | | | | | | | | | | | | | | | | | | | | | | | | | | | | | | | | | | | | | | | | | | | | | | | | | | | | | | |
| Type 640-20 standard design | | | | | | | | | | | | | | | | | | | | | | | | | | | | | | | | | | | | | | | | | | | | | | | | | | | | | | | | | | | | | | | | | | | | | | | | | | | | | | | | | | | | | | | | | | | | | | | | | | | | | | | | | | | | | | | | | | | | | | | | | | | | | | | | | | | | | | | | | | | | | | | | | | | | | | | | | | | | | | | | | | | | | | | | | | | | | | | | | | | | | | | | | | | | | | | | | | | | | | | | | | | | | | | | | | | | | | | | | | | | | | | | | | | | | | | | | | | | | | | | | | | | | | | | | | | | | | | | | | | | | | | | | | | | | | | | | | | | | | | | | | | | | | | | | | | | | | | | | | | | | | | | | | | | | | | | | | | | | | | | | | | | | | | | | | | | | | | | | | | | | | | | | | | | | | | | | | | | | | | | | | | | | | | | | | | | | | | | | | | | | | | | | | | | | | | | | | | | | | | | | | | | | | | | | | | | | | | | | | | | | | | | | | | | | | | | | | | | | | | | | | | | | | | | | | | | | | | | | | | | | | | | | | | | | | | | | | | | | | | | | | | | | | | | | | | | | | | | | | | | | | | | | | | | | | | | | | | | | | | | | | | | | | | | | | | | | | | | | | | | | | | | | | | | | | | | | | | | | | | | | | | | | | | | | | | | | | | | | | | | | | | | | | | | | | | | | | | | | | | | | | | | | | | | | | | | | | | | | | | | | | | | | | | | | | | | | | | | | | | | | | | | | | | | | | | | | | | | | | | | | | | | | | | | | | | | | | | | | | | | | | | | | | | | | | | | | | | | | | | | | | | | | | | | | | | | | | | | | | | | | | | | | | | | | | | | | | | | | | | | | | | | | | | | | | | | | | | | | | | | | | | | | | | | | | | | | | | | | | | | | | | | | | | | | | | | | | | |
| Type 640-80 with draw-off nut | | | | | | | | | | | | | 2011 | | | | | | | | | | | | | | | | | | | | | | | | | | | | | | | | | | | | | | | | | | | | | | | | | | | | | | | | | | | | | | | | | | | | | | | | | | | | | | | | | | | | | | | | | | | | | | | | | | | | | | | | | | | | | | | | | | | | | | | | | | | | | | | | | | | | | | | | | | | | | | | | | | | | | | | | | | | | | | | | | | | | | | | | | | | | | | | | | | | | | | | | | | | | | | | | | | | | | | | | | | | | | | | | | | | | | | | | | | | | | | | | | | | | | | | | | | | | | | | | | | | | | | | | | | | | | | | | | | | | | | | | | | | | | | | | | | | | | | | | | | | | | | | | | | | | | | | | | | | | | | | | | | | | | | | | | | | | | | | | | | | | | | | | | | | | | | | | | | | | | | | | | | | | | | | | | | | | | | | | | | | | | | | | | | | | | | | | | | | | | | | | | | | | | | | | | | | | | | | | | | | | | | | | | | | | | | | | | | | | | | | | | | | | | | | | | | | | | | | | | | | | | | | | | | | | | | | | | | | | | | | | | | | | | | | | | | | | | | | | | | | | | | | | | | | | | | | | | | | | | | | | | | | | | | | | | | | | | | | | | | | | | | | | | | | | | | | | | | | | | | | | | | | | | | | | | | | | | | | | | | | | | | | | | | | | | | | | | | | | | | | | | | | | | | | | | | | | | | | | | | | | | | | | | | | | | | | | | | | | | | | | | | | | | | | | | | | | | | | | | | | | | | | | | | | | | | | | | | | | | | | | | | | | | | | | | | | | | | | | | | | | | | | | | | | | | | | | | | | | | | | | | | | | | | | | | | | | | | | | | | | | | | | | | | | | | | | | | | | | | | | | | | | | | | | | | | | | | | | | | | | | | | | | | | | | | | | | | | | | | | |
| Pressure display, length compensation (Type 652) | | | | | | | | | | | | | 2013 | | | | | | | | | | | | | | | | | | | | | | | | | | | | | | | | | | | | | | | | | | | | | | | | | | | | | | | | | | | | | | | | | | | | | | | | | | | | | | | | | | | | | | | | | | | | | | | | | | | | | | | | | | | | | | | | | | | | | | | | | | | | | | | | | | | | | | | | | | | | | | | | | | | | | | | | | | | | | | | | | | | | | | | | | | | | | | | | | | | | | | | | | | | | | | | | | | | | | | | | | | | | | | | | | | | | | | | | | | | | | | | | | | | | | | | | | | | | | | | | | | | | | | | | | | | | | | | | | | | | | | | | | | | | | | | | | | | | | | | | | | | | | | | | | | | | | | | | | | | | | | | | | | | | | | | | | | | | | | | | | | | | | | | | | | | | | | | | | | | | | | | | | | | | | | | | | | | | | | | | | | | | | | | | | | | | | | | | | | | | | | | | | | | | | | | | | | | | | | | | | | | | | | | | | | | | | | | | | | | | | | | | | | | | | | | | | | | | | | | | | | | | | | | | | | | | | | | | | | | | | | | | | | | | | | | | | | | | | | | | | | | | | | | | | | | | | | | | | | | | | | | | | | | | | | | | | | | | | | | | | | | | | | | | | | | | | | | | | | | | | | | | | | | | | | | | | | | | | | | | | | | | | | | | | | | | | | | | | | | | | | | | | | | | | | | | | | | | | | | | | | | | | | | | | | | | | | | | | | | | | | | | | | | | | | | | | | | | | | | | | | | | | | | | | | | | | | | | | | | | | | | | | | | | | | | | | | | | | | | | | | | | | | | | | | | | | | | | | | | | | | | | | | | | | | | | | | | | | | | | | | | | | | | | | | | | | | | | | | | | | | | | | | | | | | | | | | | | | | | | | | | | | | | | | | | | | | | | | | | | | | |
| Type 652 AC standard design | | | | | | | | | | | | | | | | | | | | | | | | | | | | | | | | | | | | | | | | | | | | | | | | | | | | | | | | | | | | | | | | | | | | | | | | | | | | | | | | | | | | | | | | | | | | | | | | | | | | | | | | | | | | | | | | | | | | | | | | | | | | | | | | | | | | | | | | | | | | | | | | | | | | | | | | | | | | | | | | | | | | | | | | | | | | | | | | | | | | | | | | | | | | | | | | | | | | | | | | | | | | | | | | | | | | | | | | | | | | | | | | | | | | | | | | | | | | | | | | | | | | | | | | | | | | | | | | | | | | | | | | | | | | | | | | | | | | | | | | | | | | | | | | | | | | | | | | | | | | | | | | | | | | | | | | | | | | | | | | | | | | | | | | | | | | | | | | | | | | | | | | | | | | | | | | | | | | | | | | | | | | | | | | | | | | | | | | | | | | | | | | | | | | | | | | | | | | | | | | | | | | | | | | | | | | | | | | | | | | | | | | | | | | | | | | | | | | | | | | | | | | | | | | | | | | | | | | | | | | | | | | | | | | | | | | | | | | | | | | | | | | | | | | | | | | | | | | | | | | | | | | | | | | | | | | | | | | | | | | | | | | | | | | | | | | | | | | | | | | | | | | | | | | | | | | | | | | | | | | | | | | | | | | | | | | | | | | | | | | | | | | | | | | | | | | | | | | | | | | | | | | | | | | | | | | | | | | | | | | | | | | | | | | | | | | | | | | | | | | | | | | | | | | | | | | | | | | | | | | | | | | | | | | | | | | | | | | | | | | | | | | | | | | | | | | | | | | | | | | | | | | | | | | | | | | | | | | | | | | | | | | | | | | | | | | | | | | | | | | | | | | | | | | | | | | | | | | | | | | | | | | | | | | | | | | | | | | | | | | | | | | | | | | | | | | | | | |
| Type 652 AC-VL extended live centre | | | | | | | | | | | | | 2014 | | | | | | | | | | | | | | | | | | | | | | | | | | | | | | | | | | | | | | | | | | | | | | | | | | | | | | | | | | | | | | | | | | | | | | | | | | | | | | | | | | | | | | | | | | | | | | | | | | | | | | | | | | | | | | | | | | | | | | | | | | | | | | | | | | | | | | | | | | | | | | | | | | | | | | | | | | | | | | | | | | | | | | | | | | | | | | | | | | | | | | | | | | | | | | | | | | | | | | | | | | | | | | | | | | | | | | | | | | | | | | | | | | | | | | | | | | | | | | | | | | | | | | | | | | | | | | | | | | | | | | | | | | | | | | | | | | | | | | | | | | | | | | | | | | | | | | | | | | | | | | | | | | | | | | | | | | | | | | | | | | | | | | | | | | | | | | | | | | | | | | | | | | | | | | | | | | | | | | | | | | | | | | | | | | | | | | | | | | | | | | | | | | | | | | | | | | | | | | | | | | | | | | | | | | | | | | | | | | | | | | | | | | | | | | | | | | | | | | | | | | | | | | | | | | | | | | | | | | | | | | | | | | | | | | | | | | | | | | | | | | | | | | | | | | | | | | | | | | | | | | | | | | | | | | | | | | | | | | | | | | | | | | | | | | | | | | | | | | | | | | | | | | | | | | | | | | | | | | | | | | | | | | | | | | | | | | | | | | | | | | | | | | | | | | | | | | | | | | | | | | | | | | | | | | | | | | | | | | | | | | | | | | | | | | | | | | | | | | | | | | | | | | | | | | | | | | | | | | | | | | | | | | | | | | | | | | | | | | | | | | | | | | | | | | | | | | | | | | | | | | | | | | | | | | | | | | | | | | | | | | | | | | | | | | | | | | | | | | | | | | | | | | | | | | | | | | | | | | | | | | | | | | | | | | | | | | | | | | | | | | |
| Other | | | | | | | | | | | | | 2010 | | | | | | | | | | | | | | | | | | | | | | | | | | | | | | | | | | | | | | | | | | | | | | | | | | | | | | | | | | | | | | | | | | | | | | | | | | | | | | | | | | | | | | | | | | | | | | | | | | | | | | | | | | | | | | | | | | | | | | | | | | | | | | | | | | | | | | | | | | | | | | | | | | | | | | | | | | | | | | | | | | | | | | | | | | | | | | | | | | | | | | | | | | | | | | | | | | | | | | | | | | | | | | | | | | | | | | | | | | | | | | | | | | | | | | | | | | | | | | | | | | | | | | | | | | | | | | | | | | | | | | | | | | | | | | | | | | | | | | | | | | | | | | | | | | | | | | | | | | | | | | | | | | | | | | | | | | | | | | | | | | | | | | | | | | | | | | | | | | | | | | | | | | | | | | | | | | | | | | | | | | | | | | | | | | | | | | | | | | | | | | | | | | | | | | | | | | | | | | | | | | | | | | | | | | | | | | | | | | | | | | | | | | | | | | | | | | | | | | | | | | | | | | | | | | | | | | | | | | | | | | | | | | | | | | | | | | | | | | | | | | | | | | | | | | | | | | | | | | | | | | | | | | | | | | | | | | | | | | | | | | | | | | | | | | | | | | | | | | | | | | | | | | | | | | | | | | | | | | | | | | | | | | | | | | | | | | | | | | | | | | | | | | | | | | | | | | | | | | | | | | | | | | | | | | | | | | | | | | | | | | | | | | | | | | | | | | | | | | | | | | | | | | | | | | | | | | | | | | | | | | | | | | | | | | | | | | | | | | | | | | | | | | | | | | | | | | | | | | | | | | | | | | | | | | | | | | | | | | | | | | | | | | | | | | | | | | | | | | | | | | | | | | | | | | | | | | | | | | | | | | | | | | | | | | | | | | | | | | | | | | |
| Type 624 HZ with centre bore | | | | | | | | | | | | | | | | | | | | | | | | | | | | | | | | | | | | | | | | | | | | | | | | | | | | | | | | | | | | | | | | | | | | | | | | | | | | | | | | | | | | | | | | | | | | | | | | | | | | | | | | | | | | | | | | | | | | | | | | | | | | | | | | | | | | | | | | | | | | | | | | | | | | | | | | | | | | | | | | | | | | | | | | | | | | | | | | | | | | | | | | | | | | | | | | | | | | | | | | | | | | | | | | | | | | | | | | | | | | | | | | | | | | | | | | | | | | | | | | | | | | | | | | | | | | | | | | | | | | | | | | | | | | | | | | | | | | | | | | | | | | | | | | | | | | | | | | | | | | | | | | | | | | | | | | | | | | | | | | | | | | | | | | | | | | | | | | | | | | | | | | | | | | | | | | | | | | | | | | | | | | | | | | | | | | | | | | | | | | | | | | | | | | | | | | | | | | | | | | | | | | | | | | | | | | | | | | | | | | | | | | | | | | | | | | | | | | | | | | | | | | | | | | | | | | | | | | | | | | | | | | | | | | | | | | | | | | | | | | | | | | | | | | | | | | | | | | | | | | | | | | | | | | | | | | | | | | | | | | | | | | | | | | | | | | | | | | | | | | | | | | | | | | | | | | | | | | | | | | | | | | | | | | | | | | | | | | | | | | | | | | | | | | | | | | | | | | | | | | | | | | | | | | | | | | | | | | | | | | | | | | | | | | | | | | | | | | | | | | | | | | | | | | | | | | | | | | | | | | | | | | | | | | | | | | | | | | | | | | | | | | | | | | | | | | | | | | | | | | | | | | | | | | | | | | | | | | | | | | | | | | | | | | | | | | | | | | | | | | | | | | | | | | | | | | | | | | | | | | | | | | | | | | | | | | | | | | | | | | | | | | | | | | | | | | | | | |
| Type 615 impact damping | | | | | | | | | | | | | | | | | | | | | | | | | | | | | | | | | | | | | | | | | | | | | | | | | | | | | | | | | | | | | | | | | | | | | | | | | | | | | | | | | | | | | | | | | | | | | | | | | | | | | | | | | | | | | | | | | | | | | | | | | | | | | | | | | | | | | | | | | | | | | | | | | | | | | | | | | | | | | | | | | | | | | | | | | | | | | | | | | | | | | | | | | | | | | | | | | | | | | | | | | | | | | | | | | | | | | | | | | | | | | | | | | | | | | | | | | | | | | | | | | | | | | | | | | | | | | | | | | | | | | | | | | | | | | | | | | | | | | | | | | | | | | | | | | | | | | | | | | | | | | | | | | | | | | | | | | | | | | | | | | | | | | | | | | | | | | | | | | | | | | | | | | | | | | | | | | | | | | | | | | | | | | | | | | | | | | | | | | | | | | | | | | | | | | | | | | | | | | | | | | | | | | | | | | | | | | | | | | | | | | | | | | | | | | | | | | | | | | | | | | | | | | | | | | | | | | | | | | | | | | | | | | | | | | | | | | | | | | | | | | | | | | | | | | | | | | | | | | | | | | | | | | | | | | | | | | | | | | | | | | | | | | | | | | | | | | | | | | | | | | | | | | | | | | | | | | | | | | | | | | | | | | | | | | | | | | | | | | | | | | | | | | | | | | | | | | | | | | | | | | | | | | | | | | | | | | | | | | | | | | | | | | | | | | | | | | | | | | | | | | | | | | | | | | | | | | | | | | | | | | | | | | | | | | | | | | | | | | | | | | | | | | | | | | | | | | | | | | | | | | | | | | | | | | | | | | | | | | | | | | | | | | | | | | | | | | | | | | | | | | | | | | | | | | | | | | | | | | | | | | | | | | | | | | | | | | | | | | | | | | | | | | | | | | | | | | | | |
| Type 663 for especially high speeds, different head-Ø at same size of shank | | | | | | | | | | | | | | | | | | | | | | | | | | | | | | | | | | | | | | | | | | | | | | | | | | | | | | | | | | | | | | | | | | | | | | | | | | | | | | | | | | | | | | | | | | | | | | | | | | | | | | | | | | | | | | | | | | | | | | | | | | | | | | | | | | | | | | | | | | | | | | | | | | | | | | | | | | | | | | | | | | | | | | | | | | | | | | | | | | | | | | | | | | | | | | | | | | | | | | | | | | | | | | | | | | | | | | | | | | | | | | | | | | | | | | | | | | | | | | | | | | | | | | | | | | | | | | | | | | | | | | | | | | | | | | | | | | | | | | | | | | | | | | | | | | | | | | | | | | | | | | | | | | | | | | | | | | | | | | | | | | | | | | | | | | | | | | | | | | | | | | | | | | | | | | | | | | | | | | | | | | | | | | | | | | | | | | | | | | | | | | | | | | | | | | | | | | | | | | | | | | | | | | | | | | | | | | | | | | | | | | | | | | | | | | | | | | | | | | | | | | | | | | | | | | | | | | | | | | | | | | | | | | | | | | | | | | | | | | | | | | | | | | | | | | | | | | | | | | | | | | | | | | | | | | | | | | | | | | | | | | | | | | | | | | | | | | | | | | | | | | | | | | | | | | | | | | | | | | | | | | | | | | | | | | | | | | | | | | | | | | | | | | | | | | | | | | | | | | | | | | | | | | | | | | | | | | | | | | | | | | | | | | | | | | | | | | | | | | | | | | | | | | | | | | | | | | | | | | | | | | | | | | | | | | | | | | | | | | | | | | | | | | | | | | | | | | | | | | | | | | | | | | | | | | | | | | | | | | | | | | | | | | | | | | | | | | | | | | | | | | | | | | | | | | | | | | | | | | | | | | | | | | | | | | | | | | | | | | | | | | | | | | | | | | | | | | | |
| Type 664 extended NC-centre with carbide insert | | | | | | | | | | | | | | | | | | | | | | | | | | | | | | | | | | | | | | | | | | | | | | | | | | | | | | | | | | | | | | | | | | | | | | | | | | | | | | | | | | | | | | | | | | | | | | | | | | | | | | | | | | | | | | | | | | | | | | | | | | | | | | | | | | | | | | | | | | | | | | | | | | | | | | | | | | | | | | | | | | | | | | | | | | | | | | | | | | | | | | | | | | | | | | | | | | | | | | | | | | | | | | | | | | | | | | | | | | | | | | | | | | | | | | | | | | | | | | | | | | | | | | | | | | | | | | | | | | | | | | | | | | | | | | | | | | | | | | | | | | | | | | | | | | | | | | | | | | | | | | | | | | | | | | | | | | | | | | | | | | | | | | | | | | | | | | | | | | | | | | | | | | | | | | | | | | | | | | | | | | | | | | | | | | | | | | | | | | | | | | | | | | | | | | | | | | | | | | | | | | | | | | | | | | | | | | | | | | | | | | | | | | | | | | | | | | | | | | | | | | | | | | | | | | | | | | | | | | | | | | | | | | | | | | | | | | | | | | | | | | | | | | | | | | | | | | | | | | | | | | | | | | | | | | | | | | | | | | | | | | | | | | | | | | | | | | | | | | | | | | | | | | | | | | | | | | | | | | | | | | | | | | | | | | | | | | | | | | | | | | | | | | | | | | | | | | | | | | | | | | | | | | | | | | | | | | | | | | | | | | | | | | | | | | | | | | | | | | | | | | | | | | | | | | | | | | | | | | | | | | | | | | | | | | | | | | | | | | | | | | | | | | | | | | | | | | | | | | | | | | | | | | | | | | | | | | | | | | | | | | | | | | | | | | | | | | | | | | | | | | | | | | | | | | | | | | | | | | | | | | | | | | | | | | | | | | | | | | | | | | | | | | | | | | | | | | | |
| Type 614 for interchangeable inserts | | | | | | | | | | | | | 2016 | | | | | | | | | | | | | | | | | | | | | | | | | | | | | | | | | | | | | | | | | | | | | | | | | | | | | | | | | | | | | | | | | | | | | | | | | | | | | | | | | | | | | | | | | | | | | | | | | | | | | | | | | | | | | | | | | | | | | | | | | | | | | | | | | | | | | | | | | | | | | | | | | | | | | | | | | | | | | | | | | | | | | | | | | | | | | | | | | | | | | | | | | | | | | | | | | | | | | | | | | | | | | | | | | | | | | | | | | | | | | | | | | | | | | | | | | | | | | | | | | | | | | | | | | | | | | | | | | | | | | | | | | | | | | | | | | | | | | | | | | | | | | | | | | | | | | | | | | | | | | | | | | | | | | | | | | | | | | | | | | | | | | | | | | | | | | | | | | | | | | | | | | | | | | | | | | | | | | | | | | | | | | | | | | | | | | | | | | | | | | | | | | | | | | | | | | | | | | | | | | | | | | | | | | | | | | | | | | | | | | | | | | | | | | | | | | | | | | | | | | | | | | | | | | | | | | | | | | | | | | | | | | | | | | | | | | | | | | | | | | | | | | | | | | | | | | | | | | | | | | | | | | | | | | | | | | | | | | | | | | | | | | | | | | | | | | | | | | | | | | | | | | | | | | | | | | | | | | | | | | | | | | | | | | | | | | | | | | | | | | | | | | | | | | | | | | | | | | | | | | | | | | | | | | | | | | | | | | | | | | | | | | | | | | | | | | | | | | | | | | | | | | | | | | | | | | | | | | | | | | | | | | | | | | | | | | | | | | | | | | | | | | | | | | | | | | | | | | | | | | | | | | | | | | | | | | | | | | | | | | | | | | | | | | | | | | | | | | | | | | | | | | | | | | | | | | | | | | | | | | | | | | | | | | | | | | | | | | | | | | | |
| n= speed max. min ⁻¹ RO= Concentricity deviation | | | | | | | | | | | | | 4 | | | | | | | | | | | | | | | | | | | | | | | | | | | | | | | | | | | | | | | | | | | | | | | | | | | | | | | | | | | | | | | | | | | | | | | | | | | | | | | | | | | | | | | | | | | | | | | | | | | | | | | | | | | | | | | | | | | | | | | | | | | | | | | | | | | | | | | | | | | | | | | | | | | | | | | | | | | | | | | | | | | | | | | | | | | | | | | | | | | | | | | | | | | | | | | | | | | | | | | | | | | | | | | | | | | | | | | | | | | | | | | | | | | | | | | | | | | | | | | | | | | | | | | | | | | | | | | | | | | | | | | | | | | | | | | | | | | | | | | | | | | | | | | | | | | | | | | | | | | | | | | | | | | | | | | | | | | | | | | | | | | | | | | | | | | | | | | | | | | | | | | | | | | | | | | | | | | | | | | | | | | | | | | | | | | | | | | | | | | | | | | | | | | | | | | | | | | | | | | | | | | | | | | | | | | | | | | | | | | | | | | | | | | | | | | | | | | | | | | | | | | | | | | | | | | | | | | | | | | | | | | | | | | | | | | | | | | | | | | | | | | | | | | | | | | | | | | | | | | | | | | | | | | | | | | | | | | | | | | | | | | | | | | | | | | | | | | | | | | | | | | | | | | | | | | | | | | | | | | | | | | | | | | | | | | | | | | | | | | | | | | | | | | | | | | | | | | | | | | | | | | | | | | | | | | | | | | | | | | | | | | | | | | | | | | | | | | | | | | | | | | | | | | | | | | | | | | | | | | | | | | | | | | | | | | | | | | | | | | | | | | | | | | | | | | | | | | | | | | | | | | | | | | | | | | | | | | | | | | | | | | | | | | | | | | | | | | | | | | | | | | | | | | | | | | | | | | | | | | | | | | | | | | | | | | | | | | | | | | | | | |
| 640-20 n=7000 RO=0,005 | | | | | | | | | | | | | | | | | | | | | | | | | | | | | | | | | | | | | | | | | | | | | | | | | | | | | | | | | | | | | | | | | | | | | | | | | | | | | | | | | | | | | | | | | | | | | | | | | | | | | | | | | | | | | | | | | | | | | | | | | | | | | | | | | | | | | | | | | | | | | | | | | | | | | | | | | | | | | | | | | | | | | | | | | | | | | | | | | | | | | | | | | | | | | | | | | | | | | | | | | | | | | | | | | | | | | | | | | | | | | | | | | | | | | | | | | | | | | | | | | | | | | | | | | | | | | | | | | | | | | | | | | | | | | | | | | | | | | | | | | | | | | | | | | | | | | | | | | | | | | | | | | | | | | | | | | | | | | | | | | | | | | | | | | | | | | | | | | | | | | | | | | | | | | | | | | | | | | | | | | | | | | | | | | | | | | | | | | | | | | | | | | | | | | | | | | | | | | | | | | | | | | | | | | | | | | | | | | | | | | | | | | | | | | | | | | | | | | | | | | | | | | | | | | | | | | | | | | | | | | | | | | | | | | | | | | | | | | | | | | | | | | | | | | | | | | | | | | | | | | | | | | | | | | | | | | | | | | | | | | | | | | | | | | | | | | | | | | | | | | | | | | | | | | | | | | | | | | | | | | | | | | | | | | | | | | | | | | | | | | | | | | | | | | | | | | | | | | | | | | | | | | | | | | | | | | | | | | | | | | | | | | | | | | | | | | | | | | | | | | | | | | | | | | | | | | | | | | | | | | | | | | | | | | | | | | | | | | | | | | | | | | | | | | | | | | | | | | | | | | | | | | | | | | | | | | | | | | | | | | | | | | | | | | | | | | | | | | | | | | | | | | | | | | | | | | | | | | | | | | | | | | | | | | | | | | | | | | | | | | | | | | | | | | | | | | | | |
| 640-80 n=7000 RO=0,005 | | | | | | | | | | | | | 5 | | | | | | | | | | | | | | | | | | | | | | | | | | | | | | | | | | | | | | | | | | | | | | | | | | | | | | | | | | | | | | | | | | | | | | | | | | | | | | | | | | | | | | | | | | | | | | | | | | | | | | | | | | | | | | | | | | | | | | | | | | | | | | | | | | | | | | | | | | | | | | | | | | | | | | | | | | | | | | | | | | | | | | | | | | | | | | | | | | | | | | | | | | | | | | | | | | | | | | | | | | | | | | | | | | | | | | | | | | | | | | | | | | | | | | | | | | | | | | | | | | | | | | | | | | | | | | | | | | | | | | | | | | | | | | | | | | | | | | | | | | | | | | | | | | | | | | | | | | | | | | | | | | | | | | | | | | | | | | | | | | | | | | | | | | | | | | | | | | | | | | | | | | | | | | | | | | | | | | | | | | | | | | | | | | | | | | | | | | | | | | | | | | | | | | | | | | | | | | | | | | | | | | | | | | | | | | | | | | | | | | | | | | | | | | | | | | | | | | | | | | | | | | | | | | | | | | | | | | | | | | | | | | | | | | | | | | | | | | | | | | | | | | | | | | | | | | | | | | | | | | | | | | | | | | | | | | | | | | | | | | | | | | | | | | | | | | | | | | | | | | | | | | | | | | | | | | | | | | | | | | | | | | | | | | | | | | | | | | | | | | | | | | | | | | | | | | | | | | | | | | | | | | | | | | | | | | | | | | | | | | | | | | | | | | | | | | | | | | | | | | | | | | | | | | | | | | | | | | | | | | | | | | | | | | | | | | | | | | | | | | | | | | | | | | | | | | | | | | | | | | | | | | | | | | | | | | | | | | | | | | | | | | | | | | | | | | | | | | | | | | | | | | | | | | | | | | | | | | | | | | | | | | | | | | | | | | | | | | | | | | |
| 604 HM n=3000 RO=0,005 | | | | | | | | | | | | | | | | | | | | | | | | | | | | | | | | | | | | | | | | | | | | | | | | | | | | | | | | | | | | | | | | | | | | | | | | | | | | | | | | | | | | | | | | | | | | | | | | | | | | | | | | | | | | | | | | | | | | | | | | | | | | | | | | | | | | | | | | | | | | | | | | | | | | | | | | | | | | | | | | | | | | | | | | | | | | | | | | | | | | | | | | | | | | | | | | | | | | | | | | | | | | | | | | | | | | | | | | | | | | | | | | | | | | | | | | | | | | | | | | | | | | | | | | | | | | | | | | | | | | | | | | | | | | | | | | | | | | | | | | | | | | | | | | | | | | | | | | | | | | | | | | | | | | | | | | | | | | | | | | | | | | | | | | | | | | | | | | | | | | | | | | | | | | | | | | | | | | | | | | | | | | | | | | | | | | | | | | | | | | | | | | | | | | | | | | | | | | | | | | | | | | | | | | | | | | | | | | | | | | | | | | | | | | | | | | | | | | | | | | | | | | | | | | | | | | | | | | | | | | | | | | | | | | | | | | | | | | | | | | | | | | | | | | | | | | | | | | | | | | | | | | | | | | | | | | | | | | | | | | | | | | | | | | | | | | | | | | | | | | | | | | | | | | | | | | | | | | | | | | | | | | | | | | | | | | | | | | | | | | | | | | | | | | | | | | | | | | | | | | | | | | | | | | | | | | | | | | | | | | | | | | | | | | | | | | | | | | | | | | | | | | | | | | | | | | | | | | | | | | | | | | | | | | | | | | | | | | | | | | | | | | | | | | | | | | | | | | | | | | | | | | | | | | | | | | | | | | | | | | | | | | | | | | | | | | | | | | | | | | | | | | | | | | | | | | | | | | | | | | | | | | | | | | | | | | | | | | | | | | | | | | | | | | | | | | | | | |
| 652 ACVL n=2500 RO=0,01 | | | | | | | | | | | | | | | | | | | | | | | | | | | | | | | | | | | | | | | | | | | | | | | | | | | | | | | | | | | | | | | | | | | | | | | | | | | | | | | | | | | | | | | | | | | | | | | | | | | | | | | | | | | | | | | | | | | | | | | | | | | | | | | | | | | | | | | | | | | | | | | | | | | | | | | | | | | | | | | | | | | | | | | | | | | | | | | | | | | | | | | | | | | | | | | | | | | | | | | | | | | | | | | | | | | | | | | | | | | | | | | | | | | | | | | | | | | | | | | | | | | | | | | | | | | | | | | | | | | | | | | | | | | | | | | | | | | | | | | | | | | | | | | | | | | | | | | | | | | | | | | | | | | | | | | | | | | | | | | | | | | | | | | | | | | | | | | | | | | | | | | | | | | | | | | | | | | | | | | | | | | | | | | | | | | | | | | | | | | | | | | | | | | | | | | | | | | | | | | | | | | | | | | | | | | | | | | | | | | | | | | | | | | | | | | | | | | | | | | | | | | | | | | | | | | | | | | | | | | | | | | | | | | | | | | | | | | | | | | | | | | | | | | | | | | | | | | | | | | | | | | | | | | | | | | | | | | | | | | | | | | | | | | | | | | | | | | | | | | | | | | | | | | | | | | | | | | | | | | | | | | | | | | | | | | | | | | | | | | | | | | | | | | | | | | | | | | | | | | | | | | | | | | | | | | | | | | | | | | | | | | | | | | | | | | | | | | | | | | | | | | | | | | | | | | | | | | | | | | | | | | | | | | | | | | | | | | | | | | | | | | | | | | | | | | | | | | | | | | | | | | | | | | | | | | | | | | | | | | | | | | | | | | | | | | | | | | | | | | | | | | | | | | | | | | | | | | | | | | | | | | | | | | | | | | | | | | | | | | | | | | | | | | | | | | | | | | |
| 604 HVL n=3000 RO=0,005 | | | | | | | | | | | | | | | | | | | | | | | | | | | | | | | | | | | | | | | | | | | | | | | | | | | | | | | | | | | | | | | | | | | | | | | | | | | | | | | | | | | | | | | | | | | | | | | | | | | | | | | | | | | | | | | | | | | | | | | | | | | | | | | | | | | | | | | | | | | | | | | | | | | | | | | | | | | | | | | | | | | | | | | | | | | | | | | | | | | | | | | | | | | | | | | | | | | | | | | | | | | | | | | | | | | | | | | | | | | | | | | | | | | | | | | | | | | | | | | | | | | | | | | | | | | | | | | | | | | | | | | | | | | | | | | | | | | | | | | | | | | | | | | | | | | | | | | | | | | | | | | | | | | | | | | | | | | | | | | | | | | | | | | | | | | | | | | | | | | | | | | | | | | | | | | | | | | | | | | | | | | | | | | | | | | | | | | | | | | | | | | | | | | | | | | | | | | | | | | | | | | | | | | | | | | | | | | | | | | | | | | | | | | | | | | | | | | | | | | | | | | | | | | | | | | | | | | | | | | | | | | | | | | | | | | | | | | | | | | | | | | | | | | | | | | | | | | | | | | | | | | | | | | | | | | | | | | | | | | | | | | | | | | | | | | | | | | | | | | | | | | | | | | | | | | | | | | | | | | | | | | | | | | | | | | | | | | | | | | | | | | | | | | | | | | | | | | | | | | | | | | | | | | | | | | | | | | | | | | | | | | | | | | | | | | | | | | | | | | | | | | | | | | | | | | | | | | | | | | | | | | | | | | | | | | | | | | | | | | | | | | | | | | | | | | | | | | | | | | | | | | | | | | | | | | | | | | | | | | | | | | | | | | | | | | | | | | | | | | | | | | | | | | | | | | | | | | | | | | | | | | | | | | | | | | | | | | | | | | | | | | | | | | | | | | | | | | |
| 663 n=10000 RO=0,005 | | | | | | | | | | | | | 6 | | | | | | | | | | | | | | | | | | | | | | | | | | | | | | | | | | | | | | | | | | | | | | | | | | | | | | | | | | | | | | | | | | | | | | | | | | | | | | | | | | | | | | | | | | | | | | | | | | | | | | | | | | | | | | | | | | | | | | | | | | | | | | | | | | | | | | | | | | | | | | | | | | | | | | | | | | | | | | | | | | | | | | | | | | | | | | | | | | | | | | | | | | | | | | | | | | | | | | | | | | | | | | | | | | | | | | | | | | | | | | | | | | | | | | | | | | | | | | | | | | | | | | | | | | | | | | | | | | | | | | | | | | | | | | | | | | | | | | | | | | | | | | | | | | | | | | | | | | | | | | | | | | | | | | | | | | | | | | | | | | | | | | | | | | | | | | | | | | | | | | | | | | | | | | | | | | | | | | | | | | | | | | | | | | | | | | | | | | | | | | | | | | | | | | | | | | | | | | | | | | | | | | | | | | | | | | | | | | | | | | | | | | | | | | | | | | | | | | | | | | | | | | | | | | | | | | | | | | | | | | | | | | | | | | | | | | | | | | | | | | | | | | | | | | | | | | | | | | | | | | | | | | | | | | | | | | | | | | | | | | | | | | | | | | | | | | | | | | | | | | | | | | | | | | | | | | | | | | | | | | | | | | | | | | | | | | | | | | | | | | | | | | | | | | | | | | | | | | | | | | | | | | | | | | | | | | | | | | | | | | | | | | | | | | | | | | | | | | | | | | | | | | | | | | | | | | | | | | | | | | | | | | | | | | | | | | | | | | | | | | | | | | | | | | | | | | | | | | | | | | | | | | | | | | | | | | | | | | | | | | | | | | | | | | | | | | | | | | | | | | | | | | | | | | | | | | | | | | | | | | | | | | | | | | | | | | | | | | | | | | |
| 600-20 n=4300 RO=0,01 | | | | | | | | | | | | | | | | | | | | | | | | | | | | | | | | | | | | | | | | | | | | | | | | | | | | | | | | | | | | | | | | | | | | | | | | | | | | | | | | | | | | | | | | | | | | | | | | | | | | | | | | | | | | | | | | | | | | | | | | | | | | | | | | | | | | | | | | | | | | | | | | | | | | | | | | | | | | | | | | | | | | | | | | | | | | | | | | | | | | | | | | | | | | | | | | | | | | | | | | | | | | | | | | | | | | | | | | | | | | | | | | | | | | | | | | | | | | | | | | | | | | | | | | | | | | | | | | | | | | | | | | | | | | | | | | | | | | | | | | | | | | | | | | | | | | | | | | | | | | | | | | | | | | | | | | | | | | | | | | | | | | | | | | | | | | | | | | | | | | | | | | | | | | | | | | | | | | | | | | | | | | | | | | | | | | | | | | | | | | | | | | | | | | | | | | | | | | | | | | | | | | | | | | | | | | | | | | | | | | | | | | | | | | | | | | | | | | | | | | | | | | | | | | | | | | | | | | | | | | | | | | | | | | | | | | | | | | | | | | | | | | | | | | | | | | | | | | | | | | | | | | | | | | | | | | | | | | | | | | | | | | | | | | | | | | | | | | | | | | | | | | | | | | | | | | | | | | | | | | | | | | | | | | | | | | | | | | | | | | | | | | | | | | | | | | | | | | | | | | | | | | | | | | | | | | | | | | | | | | | | | | | | | | | | | | | | | | | | | | | | | | | | | | | | | | | | | | | | | | | | | | | | | | | | | | | | | | | | | | | | | | | | | | | | | | | | | | | | | | | | | | | | | | | | | | | | | | | | | | | | | | | | | | | | | | | | | | | | | | | | | | | | | | | | | | | | | | | | | | | | | | | | | | | | | | | | | | | | | | | | | | | | | | | | | | | | | |
| 600 n=4300 RO=0,01 | | | | | | | | | | | | | | | | | | | | | | | | | | | | | | | | | | | | | | | | | | | | | | | | | | | | | | | | | | | | | | | | | | | | | | | | | | | | | | | | | | | | | | | | | | | | | | | | | | | | | | | | | | | | | | | | | | | | | | | | | | | | | | | | | | | | | | | | | | | | | | | | | | | | | | | | | | | | | | | | | | | | | | | | | | | | | | | | | | | | | | | | | | | | | | | | | | | | | | | | | | | | | | | | | | | | | | | | | | | | | | | | | | | | | | | | | | | | | | | | | | | | | | | | | | | | | | | | | | | | | | | | | | | | | | | | | | | | | | | | | | | | | | | | | | | | | | | | | | | | | | | | | | | | | | | | | | | | | | | | | | | | | | | | | | | | | | | | | | | | | | | | | | | | | | | | | | | | | | | | | | | | | | | | | | | | | | | | | | | | | | | | | | | | | | | | | | | | | | | | | | | | | | | | | | | | | | | | | | | | | | | | | | | | | | | | | | | | | | | | | | | | | | | | | | | | | | | | | | | | | | | | | | | | | | | | | | | | | | | | | | | | | | | | | | | | | | | | | | | | | | | | | | | | | | | | | | | | | | | | | | | | | | | | | | | | | | | | | | | | | | | | | | | | | | | | | | | | | | | | | | | | | | | | | | | | | | | | | | | | | | | | | | | | | | | | | | | | | | | | | | | | | | | | | | | | | | | | | | | | | | | | | | | | | | | | | | | | | | | | | | | | | | | | | | | | | | | | | | | | | | | | | | | | | | | | | | | | | | | | | | | | | | | | | | | | | | | | | | | | | | | | | | | | | | | | | | | | | | | | | | | | | | | | | | | | | | | | | | | | | | | | | | | | | | | | | | | | | | | | | | | | | | | | | | | | | | | | | | | | | | | | | | | | | | | | | | | |
| 601 N n=3000 RO=0,005 | | | | | | | | | | | | | | | | | | | | | | | | | | | | | | | | | | | | | | | | | | | | | | | | | | | | | | | | | | | | | | | | | | | | | | | | | | | | | | | | | | | | | | | | | | | | | | | | | | | | | | | | | | | | | | | | | | | | | | | | | | | | | | | | | | | | | | | | | | | | | | | | | | | | | | | | | | | | | | | | | | | | | | | | | | | | | | | | | | | | | | | | | | | | | | | | | | | | | | | | | | | | | | | | | | | | | | | | | | | | | | | | | | | | | | | | | | | | | | | | | | | | | | | | | | | | | | | | | | | | | | | | | | | | | | | | | | | | | | | | | | | | | | | | | | | | | | | | | | | | | | | | | | | | | | | | | | | | | | | | | | | | | | | | | | | | | | | | | | | | | | | | | | | | | | | | | | | | | | | | | | | | | | | | | | | | | | | | | | | | | | | | | | | | | | | | | | | | | | | | | | | | | | | | | | | | | | | | | | | | | | | | | | | | | | | | | | | | | | | | | | | | | | | | | | | | | | | | | | | | | | | | | | | | | | | | | | | | | | | | | | | | | | | | | | | | | | | | | | | | | | | | | | | | | | | | | | | | | | | | | | | | | | | | | | | | | | | | | | | | | | | | | | | | | | | | | | | | | | | | | | | | | | | | | | | | | | | | | | | | | | | | | | | | | | | | | | | | | | | | | | | | | | | | | | | | | | | | | | | | | | | | | | | | | | | | | | | | | | | | | | | | | | | | | | | | | | | | | | | | | | | | | | | | | | | | | | | | | | | | | | | | | | | | | | | | | | | | | | | | | | | | | | | | | | | | | | | | | | | | | | | | | | | | | | | | | | | | | | | | | | | | | | | | | | | | | | | | | | | | | | | | | | | | | | | | | | | | | | | | | | | | | | | | | | | | | | | |
| 604 H n=3000 R=0,005 | | | | | | | | | | | | | 6 | | | | | | | | | | | | | | | | | | | | | | | | | | | | | | | | | | | | | | | | | | | | | | | | | | | | | | | | | | | | | | | | | | | | | | | | | | | | | | | | | | | | | | | | | | | | | | | | | | | | | | | | | | | | | | | | | | | | | | | | | | | | | | | | | | | | | | | | | | | | | | | | | | | | | | | | | | | | | | | | | | | | | | | | | | | | | | | | | | | | | | | | | | | | | | | | | | | | | | | | | | | | | | | | | | | | | | | | | | | | | | | | | | | | | | | | | | | | | | | | | | | | | | | | | | | | | | | | | | | | | | | | | | | | | | | | | | | | | | | | | | | | | | | | | | | | | | | | | | | | | | | | | | | | | | | | | | | | | | | | | | | | | | | | | | | | | | | | | | | | | | | | | | | | | | | | | | | | | | | | | | | | | | | | | | | | | | | | | | | | | | | | | | | | | | | | | | | | | | | | | | | | | | | | | | | | | | | | | | | | | | | | | | | | | | | | | | | | | | | | | | | | | | | | | | | | | | | | | | | | | | | | | | | | | | | | | | | | | | | | | | | | | | | | | | | | | | | | | | | | | | | | | | | | | | | | | | | | | | | | | | | | | | | | | | | | | | | | | | | | | | | | | | | | | | | | | | | | | | | | | | | | | | | | | | | | | | | | | | | | | | | | | | | | | | | | | | | | | | | | | | | | | | | | | | | | | | | | | | | | | | | | | | | | | | | | | | | | | | | | | | | | | | | | | | | | | | | | | | | | | | | | | | | | | | | | | | | | | | | | | | | | | | | | | | | | | | | | | | | | | | | | | | | | | | | | | | | | | | | | | | | | | | | | | | | | | | | | | | | | | | | | | | | | | | | | | | | | | | | | | | | | | | | | | | | | | | | | | | | | | | |
| 652 AC n=2500 RO=0,01 | | | | | | | | | | | | | | | | | | | | | | | | | | | | | | | | | | | | | | | | | | | | | | | | | | | | | | | | | | | | | | | | | | | | | | | | | | | | | | | | | | | | | | | | | | | | | | | | | | | | | | | | | | | | | | | | | | | | | | | | | | | | | | | | | | | | | | | | | | | | | | | | | | | | | | | | | | | | | | | | | | | | | | | | | | | | | | | | | | | | | | | | | | | | | | | | | | | | | | | | | | | | | | | | | | | | | | | | | | | | | | | | | | | | | | | | | | | | | | | | | | | | | | | | | | | | | | | | | | | | | | | | | | | | | | | | | | | | | | | | | | | | | | | | | | | | | | | | | | | | | | | | | | | | | | | | | | | | | | | | | | | | | | | | | | | | | | | | | | | | | | | | | | | | | | | | | | | | | | | | | | | | | | | | | | | | | | | | | | | | | | | | | | | | | | | | | | | | | | | | | | | | | | | | | | | | | | | | | | | | | | | | | | | | | | | | | | | | | | | | | | | | | | | | | | | | | | | | | | | | | | | | | | | | | | | | | | | | | | | | | | | | | | | | | | | | | | | | | | | | | | | | | | | | | | | | | | | | | | | | | | | | | | | | | | | | | | | | | | | | | | | | | | | | | | | | | | | | | | | | | | | | | | | | | | | | | | | | | | | | | | | | | | | | | | | | | | | | | | | | | | | | | | | | | | | | | | | | | | | | | | | | | | | | | | | | | | | | | | | | | | | | | | | | | | | | | | | | | | | | | | | | | | | | | | | | | | | | | | | | | | | | | | | | | | | | | | | | | | | | | | | | | | | | | | | | | | | | | | | | | | | | | | | | | | | | | | | | | | | | | | | | | | | | | | | | | | | | | | | | | | | | | | | | | | | | | | | | | | | | | | | | | | | | | | | | | | | |
| 604 HP n=3000 RO=0,003 | | | | | | | | | | | | | | | | | | | | | | | | | | | | | | | | | | | | | | | | | | | | | | | | | | | | | | | | | | | | | | | | | | | | | | | | | | | | | | | | | | | | | | | | | | | | | | | | | | | | | | | | | | | | | | | | | | | | | | | | | | | | | | | | | | | | | | | | | | | | | | | | | | | | | | | | | | | | | | | | | | | | | | | | | | | | | | | | | | | | | | | | | | | | | | | | | | | | | | | | | | | | | | | | | | | | | | | | | | | | | | | | | | | | | | | | | | | | | | | | | | | | | | | | | | | | | | | | | | | | | | | | | | | | | | | | | | | | | | | | | | | | | | | | | | | | | | | | | | | | | | | | | | | | | | | | | | | | | | | | | | | | | | | | | | | | | | | | | | | | | | | | | | | | | | | | | | | | | | | | | | | | | | | | | | | | | | | | | | | | | | | | | | | | | | | | | | | | | | | | | | | | | | | | | | | | | | | | | | | | | | | | | | | | | | | | | | | | | | | | | | | | | | | | | | | | | | | | | | | | | | | | | | | | | | | | | | | | | | | | | | | | | | | | | | | | | | | | | | | | | | | | | | | | | | | | | | | | | | | | | | | | | | | | | | | | | | | | | | | | | | | | | | | | | | | | | | | | | | | | | | | | | | | | | | | | | | | | | | | | | | | | | | | | | | | | | | | | | | | | | | | | | | | | | | | | | | | | | | | | | | | | | | | | | | | | | | | | | | | | | | | | | | | | | | | | | | | | | | | | | | | | | | | | | | | | | | | | | | | | | | | | | | | | | | | | | | | | | | | | | | | | | | | | | | | | | | | | | | | | | | | | | | | | | | | | | | | | | | | | | | | | | | | | | | | | | | | | | | | | | | | | | | | | | | | | | | | | | | | | | | | | | | | | | | | | | | | |
| 604 HG n=3000 RO=0,005 | | | | | | | | | | | | | | | | | | | | | | | | | | | | | | | | | | | | | | | | | | | | | | | | | | | | | | | | | | | | | | | | | | | | | | | | | | | | | | | | | | | | | | | | | | | | | | | | | | | | | | | | | | | | | | | | | | | | | | | | | | | | | | | | | | | | | | | | | | | | | | | | | | | | | | | | | | | | | | | | | | | | | | | | | | | | | | | | | | | | | | | | | | | | | | | | | | | | | | | | | | | | | | | | | | | | | | | | | | | | | | | | | | | | | | | | | | | | | | | | | | | | | | | | | | | | | | | | | | | | | | | | | | | | | | | | | | | | | | | | | | | | | | | | | | | | | | | | | | | | | | | | | | | | | | | | | | | | | | | | | | | | | | | | | | | | | | | | | | | | | | | | | | | | | | | | | | | | | | | | | | | | | | | | | | | | | | | | | | | | | | | | | | | | | | | | | | | | | | | | | | | | | | | | | | | | | | | | | | | | | | | | | | | | | | | | | | | | | | | | | | | | | | | | | | | | | | | | | | | | | | | | | | | | | | | | | | | | | | | | | | | | | | | | | | | | | | | | | | | | | | | | | | | | | | | | | | | | | | | | | | | | | | | | | | | | | | | | | | | | | | | | | | | | | | | | | | | | | | | | | | | | | | | | | | | | | | | | | | | | | | | | | | | | | | | | | | | | | | | | | | | | | | | | | | | | | | | | | | | | | | | | | | | | | | | | | | | | | | | | | | | | | | | | | | | | | | | | | | | | | | | | | | | | | | | | | | | | | | | | | | | | | | | | | | | | | | | | | | | | | | | | | | | | | | | | | | | | | | | | | | | | | | | | | | | | | | | | | | | | | | | | | | | | | | | | | | | | | | | | | | | | | | | | | | | | | | | | | | | | | | | | | | | | | | | | | | | |
| 624 HZ n=3000 RO=0,005 | | | | | | | | | | | | | 6 | | | | | | | | | | | | | | | | | | | | | | | | | | | | | | | | | | | | | | | | | | | | | | | | | | | | | | | | | | | | | | | | | | | | | | | | | | | | | | | | | | | | | | | | | | | | | | | | | | | | | | | | | | | | | | | | | | | | | | | | | | | | | | | | | | | | | | | | | | | | | | | | | | | | | | | | | | | | | | | | | | | | | | | | | | | | | | | | | | | | | | | | | | | | | | | | | | | | | | | | | | | | | | | | | | | | | | | | | | | | | | | | | | | | | | | | | | | | | | | | | | | | | | | | | | | | | | | | | | | | | | | | | | | | | | | | | | | | | | | | | | | | | | | | | | | | | | | | | | | | | | | | | | | | | | | | | | | | | | | | | | | | | | | | | | | | | | | | | | | | | | | | | | | | | | | | | | | | | | | | | | | | | | | | | | | | | | | | | | | | | | | | | | | | | | | | | | | | | | | | | | | | | | | | | | | | | | | | | | | | | | | | | | | | | | | | | | | | | | | | | | | | | | | | | | | | | | | | | | | | | | | | | | | | | | | | | | | | | | | | | | | | | | | | | | | | | | | | | | | | | | | | | | | | | | | | | | | | | | | | | | | | | | | | | | | | | | | | | | | | | | | | | | | | | | | | | | | | | | | | | | | | | | | | | | | | | | | | | | | | | | | | | | | | | | | | | | | | | | | | | | | | | | | | | | | | | | | | | | | | | | | | | | | | | | | | | | | | | | | | | | | | | | | | | | | | | | | | | | | | | | | | | | | | | | | | | | | | | | | | | | | | | | | | | | | | | | | | | | | | | | | | | | | | | | | | | | | | | | | | | | | | | | | | | | | | | | | | | | | | | | | | | | | | | | | | | | | | | | | | | | | | | | | | | | | | | | | | | | | | | | |
| 640-20 n=6000 RO=0,005 | | | | | | | | | | | | | | | | | | | | | | | | | | | | | | | | | | | | | | | | | | | | | | | | | | | | | | | | | | | | | | | | | | | | | | | | | | | | | | | | | | | | | | | | | | | | | | | | | | | | | | | | | | | | | | | | | | | | | | | | | | | | | | | | | | | | | | | | | | | | | | | | | | | | | | | | | | | | | | | | | | | | | | | | | | | | | | | | | | | | | | | | | | | | | | | | | | | | | | | | | | | | | | | | | | | | | | | | | | | | | | | | | | | | | | | | | | | | | | | | | | | | | | | | | | | | | | | | | | | | | | | | | | | | | | | | | | | | | | | | | | | | | | | | | | | | | | | | | | | | | | | | | | | | | | | | | | | | | | | | | | | | | | | | | | | | | | | | | | | | | | | | | | | | | | | | | | | | | | | | | | | | | | | | | | | | | | | | | | | | | | | | | | | | | | | | | | | | | | | | | | | | | | | | | | | | | | | | | | | | | | | | | | | | | | | | | | | | | | | | | | | | | | | | | | | | | | | | | | | | | | | | | | | | | | | | | | | | | | | | | | | | | | | | | | | | | | | | | | | | | | | | | | | | | | | | | | | | | | | | | | | | | | | | | | | | | | | | | | | | | | | | | | | | | | | | | | | | | | | | | | | | | | | | | | | | | | | | | | | | | | | | | | | | | | | | | | | | | | | | | | | | | | | | | | | | | | | | | | | | | | | | | | | | | | | | | | | | | | | | | | | | | | | | | | | | | | | | | | | | | | | | | | | | | | | | | | | | | | | | | | | | | | | | | | | | | | | | | | | | | | | | | | | | | | | | | | | | | | | | | | | | | | | | | | | | | | | | | | | | | | | | | | | | | | | | | | | | | | | | | | | | | | | | | | | | | | | | | | | | | | | | | | | | | | | | | | | |
| 640-80 n=6000 RO=0,005 | | | | | | | | | | | | | | | | | | | | | | | | | | | | | | | | | | | | | | | | | | | | | | | | | | | | | | | | | | | | | | | | | | | | | | | | | | | | | | | | | | | | | | | | | | | | | | | | | | | | | | | | | | | | | | | | | | | | | | | | | | | | | | | | | | | | | | | | | | | | | | | | | | | | | | | | | | | | | | | | | | | | | | | | | | | | | | | | | | | | | | | | | | | | | | | | | | | | | | | | | | | | | | | | | | | | | | | | | | | | | | | | | | | | | | | | | | | | | | | | | | | | | | | | | | | | | | | | | | | | | | | | | | | | | | | | | | | | | | | | | | | | | | | | | | | | | | | | | | | | | | | | | | | | | | | | | | | | | | | | | | | | | | | | | | | | | | | | | | | | | | | | | | | | | | | | | | | | | | | | | | | | | | | | | | | | | | | | | | | | | | | | | | | | | | | | | | | | | | | | | | | | | | | | | | | | | | | | | | | | | | | | | | | | | | | | | | | | | | | | | | | | | | | | | | | | | | | | | | | | | | | | | | | | | | | | | | | | | | | | | | | | | | | | | | | | | | | | | | | | | | | | | | | | | | | | | | | | | | | | | | | | | | | | | | | | | | | | | | | | | | | | | | | | | | | | | | | | | | | | | | | | | | | | | | | | | | | | | | | | | | | | | | | | | | | | | | | | | | | | | | | | | | | | | | | | | | | | | | | | | | | | | | | | | | | | | | | | | | | | | | | | | | | | | | | | | | | | | | | | | | | | | | | | | | | | | | | | | | | | | | | | | | | | | | | | | | | | | | | | | | | | | | | | | | | | | | | | | | | | | | | | | | | | | | | | | | | | | | | | | | | | | | | | | | | | | | | | | | | | | | | | | | | | | | | | | | | | | | | | | | | | | | | | | | | | | | | |
| 624 HZ n=2600 RO=0,01 | | | | | | | | | | | | | | | | | | | | | | | | | | | | | | | | | | | | | | | | | | | | | | | | | | | | | | | | | | | | | | | | | | | | | | | | | | | | | | | | | | | | | | | | | | | | | | | | | | | | | | | | | | | | | | | | | | | | | | | | | | | | | | | | | | | | | | | | | | | | | | | | | | | | | | | | | | | | | | | | | | | | | | | | | | | | | | | | | | | | | | | | | | | | | | | | | | | | | | | | | | | | | | | | | | | | | | | | | | | | | | | | | | | | | | | | | | | | | | | | | | | | | | | | | | | | | | | | | | | | | | | | | | | | | | | | | | | | | | | | | | | | | | | | | | | | | | | | | | | | | | | | | | | | | | | | | | | | | | | | | | | | | | | | | | | | | | | | | | | | | | | | | | | | | | | | | | | | | | | | | | | | | | | | | | | | | | | | | | | | | | | | | | | | | | | | | | | | | | | | | | | | | | | | | | | | | | | | | | | | | | | | | | | | | | | | | | | | | | | | | | | | | | | | | | | | | | | | | | | | | | | | | | | | | | | | | | | | | | | | | | | | | | | | | | | | | | | | | | | | | | | | | | | | | | | | | | | | | | | | | | | | | | | | | | | | | | | | | | | | | | | | | | | | | | | | | | | | | | | | | | | | | | | | | | | | | | | | | | | | | | | | | | | | | | | | | | | | | | | | | | | | | | | | | | | | | | | | | | | | | | | | | | | | | | | | | | | | | | | | | | | | | | | | | | | | | | | | | | | | | | | | | | | | | | | | | | | | | | | | | | | | | | | | | | | | | | | | | | | | | | | | | | | | | | | | | | | | | | | | | | | | | | | | | | | | | | | | | | | | | | | | | | | | | | | | | | | | | | | | | | | | | | | | | | | | | | | | | | | | | | | | | | | | | | | | | | | |
| 604 HM n=2600 RO=0,01 | | | | | | | | | | | | | 6 | | | | | | | | | | | | | | | | | | | | | | | | | | | | | | | | | | | | | | | | | | | | | | | | | | | | | | | | | | | | | | | | | | | | | | | | | | | | | | | | | | | | | | | | | | | | | | | | | | | | | | | | | | | | | | | | | | | | | | | | | | | | | | | | | | | | | | | | | | | | | | | | | | | | | | | | | | | | | | | | | | | | | | | | | | | | | | | | | | | | | | | | | | | | | | | | | | | | | | | | | | | | | | | | | | | | | | | | | | | | | | | | | | | | | | | | | | | | | | | | | | | | | | | | | | | | | | | | | | | | | | | | | | | | | | | | | | | | | | | | | | | | | | | | | | | | | | | | | | | | | | | | | | | | | | | | | | | | | | | | | | | | | | | | | | | | | | | | | | | | | | | | | | | | | | | | | | | | | | | | | | | | | | | | | | | | | | | | | | | | | | | | | | | | | | | | | | | | | | | | | | | | | | | | | | | | | | | | | | | | | | | | | | | | | | | | | | | | | | | | | | | | | | | | | | | | | | | | | | | | | | | | | | | | | | | | | | | | | | | | | | | | | | | | | | | | | | | | | | | | | | | | | | | | | | | | | | | | | | | | | | | | | | | | | | | | | | | | | | | | | | | | | | | | | | | | | | | | | | | | | | | | | | | | | | | | | | | | | | | | | | | | | | | | | | | | | | | | | | | | | | | | | | | | | | | | | | | | | | | | | | | | | | | | | | | | | | | | | | | | | | | | | | | | | | | | | | | | | | | | | | | | | | | | | | | | | | | | | | | | | | | | | | | | | | | | | | | | | | | | | | | | | | | | | | | | | | | | | | | | | | | | | | | | | | | | | | | | | | | | | | | | | | | | | | | | | | | | | | | | | | | | | | | | | | | | | | | | | | | | | | |
| 604 HMG n=2600 RO=0,01 | | | | | | | | | | | | | | | | | | | | | | | | | | | | | | | | | | | | | | | | | | | | | | | | | | | | | | | | | | | | | | | | | | | | | | | | | | | | | | | | | | | | | | | | | | | | | | | | | | | | | | | | | | | | | | | | | | | | | | | | | | | | | | | | | | | | | | | | | | | | | | | | | | | | | | | | | | | | | | | | | | | | | | | | | | | | | | | | | | | | | | | | | | | | | | | | | | | | | | | | | | | | | | | | | | | | | | | | | | | | | | | | | | | | | | | | | | | | | | | | | | | | | | | | | | | | | | | | | | | | | | | | | | | | | | | | | | | | | | | | | | | | | | | | | | | | | | | | | | | | | | | | | | | | | | | | | | | | | | | | | | | | | | | | | | | | | | | | | | | | | | | | | | | | | | | | | | | | | | | | | | | | | | | | | | | | | | | | | | | | | | | | | | | | | | | | | | | | | | | | | | | | | | | | | | | | | | | | | | | | | | | | | | | | | | | | | | | | | | | | | | | | | | | | | | | | | | | | | | | | | | | | | | | | | | | | | | | | | | | | | | | | | | | | | | | | | | | | | | | | | | | | | | | | | | | | | | | | | | | | | | | | | | | | | | | | | | | | | | | | | | | | | | | | | | | | | | | | | | | | | | | | | | | | | | | | | | | | | | | | | | | | | | | | | | | | | | | | | | | | | | | | | | | | | | | | | | | | | | | | | | | | | | | | | | | | | | | | | | | | | | | | | | | | | | | | | | | | | | | | | | | | | | | | | | | | | | | | | | | | | | | | | | | | | | | | | | | | | | | | | | | | | | | | | | | | | | | | | | | | | | | | | | | | | | | | | | | | | | | | | | | | | | | | | | | | | | | | | | | | | | | | | | | | | | | | | | | | | | | | | | | | | | | | | | | | | | | |
| 652 AC VL n=1800 RO=0,015 | | | | | | | | | | | | | | | | | | | | | | | | | | | | | | | | | | | | | | | | | | | | | | | | | | | | | | | | | | | | | | | | | | | | | | | | | | | | | | | | | | | | | | | | | | | | | | | | | | | | | | | | | | | | | | | | | | | | | | | | | | | | | | | | | | | | | | | | | | | | | | | | | | | | | | | | | | | | | | | | | | | | | | | | | | | | | | | | | | | | | | | | | | | | | | | | | | | | | | | | | | | | | | | | | | | | | | | | | | | | | | | | | | | | | | | | | | | | | | | | | | | | | | | | | | | | | | | | | | | | | | | | | | | | | | | | | | | | | | | | | | | | | | | | | | | | | | | | | | | | | | | | | | | | | | | | | | | | | | | | | | | | | | | | | | | | | | | | | | | | | | | | | | | | | | | | | | | | | | | | | | | | | | | | | | | | | | | | | | | | | | | | | | | | | | | | | | | | | | | | | | | | | | | | | | | | | | | | | | | | | | | | | | | | | | | | | | | | | | | | | | | | | | | | | | | | | | | | | | | | | | | | | | | | | | | | | | | | | | | | | | | | | | | | | | | | | | | | | | | | | | | | | | | | | | | | | | | | | | | | | | | | | | | | | | | | | | | | | | | | | | | | | | | | | | | | | | | | | | | | | | | | | | | | | | | | | | | | | | | | | | | | | | | | | | | | | | | | | | | | | | | | | | | | | | | | | | | | | | | | | | | | | | | | | | | | | | | | | | | | | | | | | | | | | | | | | | | | | | | | | | | | | | | | | | | | | | | | | | | | | | | | | | | | | | | | | | | | | | | | | | | | | | | | | | | | | | | | | | | | | | | | | | | | | | | | | | | | | | | | | | | | | | | | | | | | | | | | | | | | | | | | | | | | | | | | | | | | | | | | | | | | | | | | | | | | | | | |
| 640-20 n=4800 RO=0,005 | | | | | | | | | | | | | | | | | | | | | | | | | | | | | | | | | | | | | | | | | | | | | | | | | | | | | | | | | | | | | | | | | | | | | | | | | | | | | | | | | | | | | | | | | | | | | | | | | | | | | | | | | | | | | | | | | | | | | | | | | | | | | | | | | | | | | | | | | | | | | | | | | | | | | | | | | | | | | | | | | | | | | | | | | | | | | | | | | | | | | | | | | | | | | | | | | | | | | | | | | | | | | | | | | | | | | | | | | | | | | | | | | | | | | | | | | | | | | | | | | | | | | | | | | | | | | | | | | | | | | | | | | | | | | | | | | | | | | | | | | | | | | | | | | | | | | | | | | | | | | | | | | | | | | | | | | | | | | | | | | | | | | | | | | | | | | | | | | | | | | | | | | | | | | | | | | | | | | | | | | | | | | | | | | | | | | | | | | | | | | | | | | | | | | | | | | | | | | | | | | | | | | | | | | | | | | | | | | | | | | | | | | | | | | | | | | | | | | | | | | | | | | | | | | | | | | | | | | | | | | | | | | | | | | | | | | | | | | | | | | | | | | | | | | | | | | | | | | | | | | | | | | | | | | | | | | | | | | | | | | | | | | | | | | | | | | | | | | | | | | | | | | | | | | | | | | | | | | | | | | | | | | | | | | | | | | | | | | | | | | | | | | | | | | | | | | | | | | | | | | | | | | | | | | | | | | | | | | | | | | | | | | | | | | | | | | | | | | | | | | | | | | | | | | | | | | | | | | | | | | | | | | | | | | | | | | | | | | | | | | | | | | | | | | | | | | | | | | | | | | | | | | | | | | | | | | | | | | | | | | | | | | | | | | | | | | | | | | | | | | | | | | | | | | | | | | | | | | | | | | | | | | | | | | | | | | | | | | | | | | | | | | | | | | | | | | | | |
| 663 n=7000 R=0,005 | | | | | | | | | | | | | 6 | | | | | | | | | | | | | | | | | | | | | | | | | | | | | | | | | | | | | | | | | | | | | | | | | | | | | | | | | | | | | | | | | | | | | | | | | | | | | | | | | | | | | | | | | | | | | | | | | | | | | | | | | | | | | | | | | | | | | | | | | | | | | | | | | | | | | | | | | | | | | | | | | | | | | | | | | | | | | | | | | | | | | | | | | | | | | | | | | | | | | | | | | | | | | | | | | | | | | | | | | | | | | | | | | | | | | | | | | | | | | | | | | | | | | | | | | | | | | | | | | | | | | | | | | | | | | | | | | | | | | | | | | | | | | | | | | | | | | | | | | | | | | | | | | | | | | | | | | | | | | | | | | | | | | | | | | | | | | | | | | | | | | | | | | | | | | | | | | | | | | | | | | | | | | | | | | | | | | | | | | | | | | | | | | | | | | | | | | | | | | | | | | | | | | | | | | | | | | | | | | | | | | | | | | | | | | | | | | | | | | | | | | | | | | | | | | | | | | | | | | | | | | | | | | | | | | | | | | | | | | | | | | | | | | | | | | | | | | | | | | | | | | | | | | | | | | | | | | | | | | | | | | | | | | | | | | | | | | | | | | | | | | | | | | | | | | | | | | | | | | | | | | | | | | | | | | | | | | | | | | | | | | | | | | | | | | | | | | | | | | | | | | | | | | | | | | | | | | | | | | | | | | | | | | | | | | | | | | | | | | | | | | | | | | | | | | | | | | | | | | | | | | | | | | | | | | | | | | | | | | | | | | | | | | | | | | | | | | | | | | | | | | | | | | | | | | | | | | | | | | | | | | | | | | | | | | | | | | | | | | | | | | | | | | | | | | | | | | | | | | | | | | | | | | | | | | | | | | | | | | | | | | | | | | | | | | | | | | | | | | | |
| 640-80 n=4800 RO=0,005 | | | | | | | | | | | | | | | | | | | | | | | | | | | | | | | | | | | | | | | | | | | | | | | | | | | | | | | | | | | | | | | | | | | | | | | | | | | | | | | | | | | | | | | | | | | | | | | | | | | | | | | | | | | | | | | | | | | | | | | | | | | | | | | | | | | | | | | | | | | | | | | | | | | | | | | | | | | | | | | | | | | | | | | | | | | | | | | | | | | | | | | | | | | | | | | | | | | | | | | | | | | | | | | | | | | | | | | | | | | | | | | | | | | | | | | | | | | | | | | | | | | | | | | | | | | | | | | | | | | | | | | | | | | | | | | | | | | | | | | | | | | | | | | | | | | | | | | | | | | | | | | | | | | | | | | | | | | | | | | | | | | | | | | | | | | | | | | | | | | | | | | | | | | | | | | | | | | | | | | | | | | | | | | | | | | | | | | | | | | | | | | | | | | | | | | | | | | | | | | | | | | | | | | | | | | | | | | | | | | | | | | | | | | | | | | | | | | | | | | | | | | | | | | | | | | | | | | | | | | | | | | | | | | | | | | | | | | | | | | | | | | | | | | | | | | | | | | | | | | | | | | | | | | | | | | | | | | | | | | | | | | | | | | | | | | | | | | | | | | | | | | | | | | | | | | | | | | | | | | | | | | | | | | | | | | | | | | | | | | | | | | | | | | | | | | | | | | | | | | | | | | | | | | | | | | | | | | | | | | | | | | | | | | | | | | | | | | | | | | | | | | | | | | | | | | | | | | | | | | | | | | | | | | | | | | | | | | | | | | | | | | | | | | | | | | | | | | | | | | | | | | | | | | | | | | | | | | | | | | | | | | | | | | | | | | | | | | | | | | | | | | | | | | | | | | | | | | | | | | | | | | | | | | | | | | | | | | | | | | | | | | | | | | | | | | | | | | |
| 604 H n=3000 RO=0,02 | | | | | | | | | | | | | 6 | | | | | | | | | | | | | | | | | | | | | | | | | | | | | | | | | | | | | | | | | | | | | | | | | | | | | | | | | | | | | | | | | | | | | | | | | | | | | | | | | | | | | | | | | | | | | | | | | | | | | | | | | | | | | | | | | | | | | | | | | | | | | | | | | | | | | | | | | | | | | | | | | | | | | | | | | | | | | | | | | | | | | | | | | | | | | | | | | | | | | | | | | | | | | | | | | | | | | | | | | | | | | | | | | | | | | | | | | | | | | | | | | | | | | | | | | | | | | | | | | | | | | | | | | | | | | | | | | | | | | | | | | | | | | | | | | | | | | | | | | | | | | | | | | | | | | | | | | | | | | | | | | | | | | | | | | | | | | | | | | | | | | | | | | | | | | | | | | | | | | | | | | | | | | | | | | | | | | | | | | | | | | | | | | | | | | | | | | | | | | | | | | | | | | | | | | | | | | | | | | | | | | | | | | | | | | | | | | | | | | | | | | | | | | | | | | | | | | | | | | | | | | | | | | | | | | | | | | | | | | | | | | | | | | | | | | | | | | | | | | | | | | | | | | | | | | | | | | | | | | | | | | | | | | | | | | | | | | | | | | | | | | | | | | | | | | | | | | | | | | | | | | | | | | | | | | | | | | | | | | | | | | | | | | | | | | | | | | | | | | | | | | | | | | | | | | | | | | | | | | | | | | | | | | | | | | | | | | | | | | | | | | | | | | | | | | | | | | | | | | | | | | | | | | | | | | | | | | | | | | | | | | | | | | | | | | | | | | | | | | | | | | | | | | | | | | | | | | | | | | | | | | | | | | | | | | | | | | | | | | | | | | | | | | | | | | | | | | | | | | | | | | | | | | | | | | | | | | | | | | | | | | | | | | | | | | | | | | | | | | | |
| 604 H n=1500 RO=0,01 | | | | | | | | | | | | | | | | | | | | | | | | | | | | | | | | | | | | | | | | | | | | | | | | | | | | | | | | | | | | | | | | | | | | | | | | | | | | | | | | | | | | | | | | | | | | | | | | | | | | | | | | | | | | | | | | | | | | | | | | | | | | | | | | | | | | | | | | | | | | | | | | | | | | | | | | | | | | | | | | | | | | | | | | | | | | | | | | | | | | | | | | | | | | | | | | | | | | | | | | | | | | | | | | | | | | | | | | | | | | | | | | | | | | | | | | | | | | | | | | | | | | | | | | | | | | | | | | | | | | | | | | | | | | | | | | | | | | | | | | | | | | | | | | | | | | | | | | | | | | | | | | | | | | | | | | | | | | | | | | | | | | | | | | | | | | | | | | | | | | | | | | | | | | | | | | | | | | | | | | | | | | | | | | | | | | | | | | | | | | | | | | | | | | | | | | | | | | | | | | | | | | | | | | | | | | | | | | | | | | | | | | | | | | | | | | | | | | | | | | | | | | | | | | | | | | | | | | | | | | | | | | | | | | | | | | | | | | | | | | | | | | | | | | | | | | | | | | | | | | | | | | | | | | | | | | | | | | | | | | | | | | | | | | | | | | | | | | | | | | | | | | | | | | | | | | | | | | | | | | | | | | | | | | | | | | | | | | | | | | | | | | | | | | | | | | | | | | | | | | | | | | | | | | | | | | | | | | | | | | | | | | | | | | | | | | | | | | | | | | | | | | | | | | | | | | | | | | | | | | | | | | | | | | | | | | | | | | | | | | | | | | | | | | | | | | | | | | | | | | | | | | | | | | | | | | | | | | | | | | | | | | | | | | | | | | | | | | | | | | | | | | | | | | | | | | | | | | | | | | | | | | | | | | | | | | | | | | | | | | | | | | | | | | | | | | | | | |
| 604 H n=2600 RO=0,01 | | | | | | | | | | | | | 6 | | | | | | | | | | | | | | | | | | | | | | | | | | | | | | | | | | | | | | | | | | | | | | | | | | | | | | | | | | | | | | | | | | | | | | | | | | | | | | | | | | | | | | | | | | | | | | | | | | | | | | | | | | | | | | | | | | | | | | | | | | | | | | | | | | | | | | | | | | | | | | | | | | | | | | | | | | | | | | | | | | | | | | | | | | | | | | | | | | | | | | | | | | | | | | | | | | | | | | | | | | | | | | | | | | | | | | | | | | | | | | | | | | | | | | | | | | | | | | | | | | | | | | | | | | | | | | | | | | | | | | | | | | | | | | | | | | | | | | | | | | | | | | | | | | | | | | | | | | | | | | | | | | | | | | | | | | | | | | | | | | | | | | | | | | | | | | | | | | | | | | | | | | | | | | | | | | | | | | | | | | | | | | | | | | | | | | | | | | | | | | | | | | | | | | | | | | | | | | | | | | | | | | | | | | | | | | | | | | | | | | | | | | | | | | | | | | | | | | | | | | | | | | | | | | | | | | | | | | | | | | | | | | | | | | | | | | | | | | | | | | | | | | | | | | | | | | | | | | | | | | | | | | | | | | | | | | | | | | | | | | | | | | | | | | | | | | | | | | | | | | | | | | | | | | | | | | | | | | | | | | | | | | | | | | | | | | | | | | | | | | | | | | | | | | | | | | | | | | | | | | | | | | | | | | | | | | | | | | | | | | | | | | | | | | | | | | | | | | | | | | | | | | | | | | | | | | | | | | | | | | | | | | | | | | | | | | | | | | | | | | | | | | | | | | | | | | | | | | | | | | | | | | | | | | | | | | | | | | | | | | | | | | | | | | | | | | | | | | | | | | | | | | | | | | | | | | | | | | | | | | | | | | | | | | | | | | | | | | | | | | |
| 604 HG n=2600 RO=0,01 | | | | | | | | | | | | | | | | | | | | | | | | | | | | | | | | | | | | | | | | | | | | | | | | | | | | | | | | | | | | | | | | | | | | | | | | | | | | | | | | | | | | | | | | | | | | | | | | | | | | | | | | | | | | | | | | | | | | | | | | | | | | | | | | | | | | | | | | | | | | | | | | | | | | | | | | | | | | | | | | | | | | | | | | | | | | | | | | | | | | | | | | | | | | | | | | | | | | | | | | | | | | | | | | | | | | | | | | | | | | | | | | | | | | | | | | | | | | | | | | | | | | | | | | | | | | | | | | | | | | | | | | | | | | | | | | | | | | | | | | | | | | | | | | | | | | | | | | | | | | | | | | | | | | | | | | | | | | | | | | | | | | | | | | | | | | | | | | | | | | | | | | | | | | | | | | | | | | | | | | | | | | | | | | | | | | | | | | | | | | | | | | | | | | | | | | | | | | | | | | | | | | | | | | | | | | | | | | | | | | | | | | | | | | | | | | | | | | | | | | | | | | | | | | | | | | | | | | | | | | | | | | | | | | | | | | | | | | | | | | | | | | | | | | | | | | | | | | | | | | | | | | | | | | | | | | | | | | | | | | | | | | | | | | | | | | | | | | | | | | | | | | | | | | | | | | | | | | | | | | | | | | | | | | | | | | | | | | | | | | | | | | | | | | | | | | | | | | | | | | | | | | | | | | | | | | | | | | | | | | | | | | | | | | | | | | | | | | | | | | | | | | | | | | | | | | | | | | | | | | | | | | | | | | | | | | | | | | | | | | | | | | | | | | | | | | | | | | | | | | | | | | | | | | | | | | | | | | | | | | | | | | | | | | | | | | | | | | | | | | | | | | | | | | | | | | | | | | | | | | | | | | | | | | | | | | | | | | | | | | | | | | | | | | | | | | | | | |
| 604 H n=3000 RO=0,005 | | | | | | | | | | | | | 5 | | | | | | | | | | | | | | | | | | | | | | | | | | | | | | | | | | | | | | | | | | | | | | | | | | | | | | | | | | | | | | | | | | | | | | | | | | | | | | | | | | | | | | | | | | | | | | | | | | | | | | | | | | | | | | | | | | | | | | | | | | | | | | | | | | | | | | | | | | | | | | | | | | | | | | | | | | | | | | | | | | | | | | | | | | | | | | | | | | | | | | | | | | | | | | | | | | | | | | | | | | | | | | | | | | | | | | | | | | | | | | | | | | | | | | | | | | | | | | | | | | | | | | | | | | | | | | | | | | | | | | | | | | | | | | | | | | | | | | | | | | | | | | | | | | | | | | | | | | | | | | | | | | | | | | | | | | | | | | | | | | | | | | | | | | | | | | | | | | | | | | | | | | | | | | | | | | | | | | | | | | | | | | | | | | | | | | | | | | | | | | | | | | | | | | | | | | | | | | | | | | | | | | | | | | | | | | | | | | | | | | | | | | | | | | | | | | | | | | | | | | | | | | | | | | | | | | | | | | | | | | | | | | | | | | | | | | | | | | | | | | | | | | | | | | | | | | | | | | | | | | | | | | | | | | | | | | | | | | | | | | | | | | | | | | | | | | | | | | | | | | | | | | | | | | | | | | | | | | | | | | | | | | | | | | | | | | | | | | | | | | | | | | | | | | | | | | | | | | | | | | | | | | | | | | | | | | | | | | | | | | | | | | | | | | | | | | | | | | | | | | | | | | | | | | | | | | | | | | | | | | | | | | | | | | | | | | | | | | | | | | | | | | | | | | | | | | | | | | | | | | | | | | | | | | | | | | | | | | | | | | | | | | | | | | | | | | | | | | | | | | | | | | | | | | | | | | | | | | | | | | | | | | | | | | | | | | | | | | | | | | |
| 604 HMG n=3000 RO=0,005 | | | | | | | | | | | | | | | | | | | | | | | | | | | | | | | | | | | | | | | | | | | | | | | | | | | | | | | | | | | | | | | | | | | | | | | | | | | | | | | | | | | | | | | | | | | | | | | | | | | | | | | | | | | | | | | | | | | | | | | | | | | | | | | | | | | | | | | | | | | | | | | | | | | | | | | | | | | | | | | | | | | | | | | | | | | | | | | | | | | | | | | | | | | | | | | | | | | | | | | | | | | | | | | | | | | | | | | | | | | | | | | | | | | | | | | | | | | | | | | | | | | | | | | | | | | | | | | | | | | | | | | | | | | | | | | | | | | | | | | | | | | | | | | | | | | | | | | | | | | | | | | | | | | | | | | | | | | | | | | | | | | | | | | | | | | | | | | | | | | | | | | | | | | | | | | | | | | | | | | | | | | | | | | | | | | | | | | | | | | | | | | | | | | | | | | | | | | | | | | | | | | | | | | | | | | | | | | | | | | | | | | | | | | | | | | | | | | | | | | | | | | | | | | | | | | | | | | | | | | | | | | | | | | | | | | | | | | | | | | | | | | | | | | | | | | | | | | | | | | | | | | | | | | | | | | | | | | | | | | | | | | | | | | | | | | | | | | | | | | | | | | | | | | | | | | | | | | | | | | | | | | | | | | | | | | | | | | | | | | | | | | | | | | | | | | | | | | | | | | | | | | | | | | | | | | | | | | | | | | | | | | | | | | | | | | | | | | | | | | | | | | | | | | | | | | | | | | | | | | | | | | | | | | | | | | | | | | | | | | | | | | | | | | | | | | | | | | | | | | | | | | | | | | | | | | | | | | | | | | | | | | | | | | | | | | | | | | | | | | | | | | | | | | | | | | | | | | | | | | | | | | | | | | | | | | | | | | | | | | | | | | | | | | | | | | | | | | |
| 624 HZ n=3000 RO=0,005 | | | | | | | | | | | | | 6 | | | | | | | | | | | | | | | | | | | | | | | | | | | | | | | | | | | | | | | | | | | | | | | | | | | | | | | | | | | | | | | | | | | | | | | | | | | | | | | | | | | | | | | | | | | | | | | | | | | | | | | | | | | | | | | | | | | | | | | | | | | | | | | | | | | | | | | | | | | | | | | | | | | | | | | | | | | | | | | | | | | | | | | | | | | | | | | | | | | | | | | | | | | | | | | | | | | | | | | | | | | | | | | | | | | | | | | | | | | | | | | | | | | | | | | | | | | | | | | | | | | | | | | | | | | | | | | | | | | | | | | | | | | | | | | | | | | | | | | | | | | | | | | | | | | | | | | | | | | | | | | | | | | | | | | | | | | | | | | | | | | | | | | | | | | | | | | | | | | | | | | | | | | | | | | | | | | | | | | | | | | | | | | | | | | | | | | | | | | | | | | | | | | | | | | | | | | | | | | | | | | | | | | | | | | | | | | | | | | | | | | | | | | | | | | | | | | | | | | | | | | | | | | | | | | | | | | | | | | | | | | | | | | | | | | | | | | | | | | | | | | | | | | | | | | | | | | | | | | | | | | | | | | | | | | | | | | | | | | | | | | | | | | | | | | | | | | | | | | | | | | | | | | | | | | | | | | | | | | | | | | | | | | | | | | | | | | | | | | | | | | | | | | | | | | | | | | | | | | | | | | | | | | | | | | | | | | | | | | | | | | | | | | | | | | | | | | | | | | | | | | | | | | | | | | | | | | | | | | | | | | | | | | | | | | | | | | | | | | | | | | | | | | | | | | | | | | | | | | | | | | | | | | | | | | | | | | | | | | | | | | | | | | | | | | | | | | | | | | | | | | | | | | | | | | | | | | | | | | | | | | | | | | | | | | | | | | | | | | | | | |
| 640-20 n=6000 RO=0,005 | | | | | | | | | | | | | | | | | | | | | | | | | | | | | | | | | | | | | | | | | | | | | | | | | | | | | | | | | | | | | | | | | | | | | | | | | | | | | | | | | | | | | | | | | | | | | | | | | | | | | | | | | | | | | | | | | | | | | | | | | | | | | | | | | | | | | | | | | | | | | | | | | | | | | | | | | | | | | | | | | | | | | | | | | | | | | | | | | | | | | | | | | | | | | | | | | | | | | | | | | | | | | | | | | | | | | | | | | | | | | | | | | | | | | | | | | | | | | | | | | | | | | | | | | | | | | | | | | | | | | | | | | | | | | | | | | | | | | | | | | | | | | | | | | | | | | | | | | | | | | | | | | | | | | | | | | | | | | | | | | | | | | | | | | | | | | | | | | | | | | | | | | | | | | | | | | | | | | | | | | | | | | | | | | | | | | | | | | | | | | | | | | | | | | | | | | | | | | | | | | | | | | | | | | | | | | | | | | | | | | | | | | | | | | | | | | | | | | | | | | | | | | | | | | | | | | | | | | | | | | | | | | | | | | | | | | | | | | | | | | | | | | | | | | | | | | | | | | | | | | | | | | | | | | | | | | | | | | | | | | | | | | | | | | | | | | | | | | | | | | | | | | | | | | | | | | | | | | | | | | | | | | | | | | | | | | | | | | | | | | | | | | | | | | | | | | | | | | | | | | | | | | | | | | | | | | | | | | | | | | | | | | | | | | | | | | | | | | | | | | | | | | | | | | | | | | | | | | | | | | | | | | | | | | | | | | | | | | | | | | | | | | | | | | | | | | | | | | | | | | | | | | | | | | | | | | | | | | | | | | | | | | | | | | | | | | | | | | | | | | | | | | | | | | | | | | | | | | | | | | | | | | | | | | | | | | | | | | | | | | | | | | | | | | | | | | | | |
| 640-80 n=6000 RO=0,005 | | | | | | | | | | | | | | | | | | | | | | | | | | | | | | | | | | | | | | | | | | | | | | | | | | | | | | | | | | | | | | | | | | | | | | | | | | | | | | | | | | | | | | | | | | | | | | | | | | | | | | | | | | | | | | | | | | | | | | | | | | | | | | | | | | | | | | | | | | | | | | | | | | | | | | | | | | | | | | | | | | | | | | | | | | | | | | | | | | | | | | | | | | | | | | | | | | | | | | | | | | | | | | | | | | | | | | | | | | | | | | | | | | | | | | | | | | | | | | | | | | | | | | | | | | | | | | | | | | | | | | | | | | | | | | | | | | | | | | | | | | | | | | | | | | | | | | | | | | | | | | | | | | | | | | | | | | | | | | | | | | | | | | | | | | | | | | | | | | | | | | | | | | | | | | | | | | | | | | | | | | | | | | | | | | | | | | | | | | | | | | | | | | | | | | | | | | | | | | | | | | | | | | | | | | | | | | | | | | | | | | | | | | | | | | | | | | | | | | | | | | | | | | | | | | | | | | | | | | | | | | | | | | | | | | | | | | | | | | | | | | | | | | | | | | | | | | | | | | | | | | | | | | | | | | | | | | | | | | | | | | | | | | | | | | | | | | | | | | | | | | | | | | | | | | | | | | | | | | | | | | | | | | | | | | | | | | | | | | | | | | | | | | | | | | | | | | | | | | | | | | | | | | | | | | | | | | | | | | | | | | | | | | | | | | | | | | | | | | | | | | | | | | | | | | | | | | | | | | | | | | | | | | | | | | | | | | | | | | | | | | | | | | | | | | | | | | | | | | | | | | | | | | | | | | | | | | | | | | | | | | | | | | | | | | | | | | | | | | | | | | | | | | | | | | | | | | | | | | | | | | | | | | | | | | | | | | | | | | | | | | | | | | | | | | | | | | | |
| 624 HZ n=2600 RO=0,01 | | | | | | | | | | | | | | | | | | | | | | | | | | | | | | | | | | | | | | | | | | | | | | | | | | | | | | | | | | | | | | | | | | | | | | | | | | | | | | | | | | | | | | | | | | | | | | | | | | | | | | | | | | | | | | | | | | | | | | | | | | | | | | | | | | | | | | | | | | | | | | | | | | | | | | | | | | | | | | | | | | | | | | | | | | | | | | | | | | | | | | | | | | | | | | | | | | | | | | | | | | | | | | | | | | | | | | | | | | | | | | | | | | | | | | | | | | | | | | | | | | | | | | | | | | | | | | | | | | | | | | | | | | | | | | | | | | | | | | | | | | | | | | | | | | | | | | | | | | | | | | | | | | | | | | | | | | | | | | | | | | | | | | | | | | | | | | | | | | | | | | | | | | | | | | | | | | | | | | | | | | | | | | | | | | | | | | | | | | | | | | | | | | | | | | | | | | | | | | | | | | | | | | | | | | | | | | | | | | | | | | | | | | | | | | | | | | | | | | | | | | | | | | | | | | | | | | | | | | | | | | | | | | | | | | | | | | | | | | | | | | | | | | | | | | | | | | | | | | | | | | | | | | | | | | | | | | | | | | | | | | | | | | | | | | | | | | | | | | | | | | | | | | | | | | | | | | | | | | | | | | | | | | | | | | | | | | | | | | | | | | | | | | | | | | | | | | | | | | | | | | | | | | | | | | | | | | | | | | | | | | | | | | | | | | | | | | | | | | | | | | | | | | | | | | | | | | | | | | | | | | | | | | | | | | | | | | | | | | | | | | | | | | | | | | | | | | | | | | | | | | | | | | | | | | | | | | | | | | | | | | | | | | | | | | | | | | | | | | | | | | | | | | | | | | | | | | | | | | | | | | | | | | | | | | | | | | | | | | | | | | | | | | | | | | | | | | | |
| 604 HM n=2600 RO=0,01 | | | | | | | | | | | | | 6 | | | | | | | | | | | | | | | | | | | | | | | | | | | | | | | | | | | | | | | | | | | | | | | | | | | | | | | | | | | | | | | | | | | | | | | | | | | | | | | | | | | | | | | | | | | | | | | | | | | | | | | | | | | | | | | | | | | | | | | | | | | | | | | | | | | | | | | | | | | | | | | | | | | | | | | | | | | | | | | | | | | | | | | | | | | | | | | | | | | | | | | | | | | | | | | | | | | | | | | | | | | | | | | | | | | | | | | | | | | | | | | | | | | | | | | | | | | | | | | | | | | | | | | | | | | | | | | | | | | | | | | | | | | | | | | | | | | | | | | | | | | | | | | | | | | | | | | | | | | | | | | | | | | | | | | | | | | | | | | | | | | | | | | | | | | | | | | | | | | | | | | | | | | | | | | | | | | | | | | | | | | | | | | | | | | | | | | | | | | | | | | | | | | | | | | | | | | | | | | | | | | | | | | | | | | | | | | | | | | | | | | | | | | | | | | | | | | | | | | | | | | | | | | | | | | | | | | | | | | | | | | | | | | | | | | | | | | | | | | | | | | | | | | | | | | | | | | | | | | | | | | | | | | | | | | | | | | | | | | | | | | | | | | | | | | | | | | | | | | | | | | | | | | | | | | | | | | | | | | | | | | | | | | | | | | | | | | | | | | | | | | | | | | | | | | | | | | | | | | | | | | | | | | | | | | | | | | | | | | | | | | | | | | | | | | | | | | | | | | | | | | | | | | | | | | | | | | | | | | | | | | | | | | | | | | | | | | | | | | | | | | | | | | | | | | | | | | | | | | | | | | | | | | | | | | | | | | | | | | | | | | | | | | | | | | | | | | | | | | | | | | | | | | | | | | | | | | | | | | | | | | | | | | | | | | | | | | | | | | | | | |
| 604 HMG n=2600 RO=0,01 | | | | | | | | | | | | | | | | | | | | | | | | | | | | | | | | | | | | | | | | | | | | | | | | | | | | | | | | | | | | | | | | | | | | | | | | | | | | | | | | | | | | | | | | | | | | | | | | | | | | | | | | | | | | | | | | | | | | | | | | | | | | | | | | | | | | | | | | | | | | | | | | | | | | | | | | | | | | | | | | | | | | | | | | | | | | | | | | | | | | | | | | | | | | | | | | | | | | | | | | | | | | | | | | | | | | | | | | | | | | | | | | | | | | | | | | | | | | | | | | | | | | | | | | | | | | | | | | | | | | | | | | | | | | | | | | | | | | | | | | | | | | | | | | | | | | | | | | | | | | | | | | | | | | | | | | | | | | | | | | | | | | | | | | | | | | | | | | | | | | | | | | | | | | | | | | | | | | | | | | | | | | | | | | | | | | | | | | | | | | | | | | | | | | | | | | | | | | | | | | | | | | | | | | | | | | | | | | | | | | | | | | | | | | | | | | | | | | | | | | | | | | | | | | | | | | | | | | | | | | | | | | | | | | | | | | | | | | | | | | | | | | | | | | | | | | | | | | | | | | | | | | | | | | | | | | | | | | | | | | | | | | | | | | | | | | | | | | | | | | | | | | | | | | | | | | | | | | | | | | | | | | | | | | | | | | | | | | | | | | | | | | | | | | | | | | | | | | | | | | | | | | | | | | | | | | | | | | | | | | | | | | | | | | | | | | | | | | | | | | | | | | | | | | | | | | | | | | | | | | | | | | | | | | | | | | | | | | | | | | | | | | | | | | | | | | | | | | | | | | | | | | | | | | | | | | | | | | | | | | | | | | | | | | | | | | | | | | | | | | | | | | | | | | | | | | | | | | | | | | | | | | | | | | | | | | | | | | | | | | | | | | | | | | | | | | | | | |
| 652 AC VL n=1800 RO=0,015 | | | | | | | | | | | | | | | | | | | | | | | | | | | | | | | | | | | | | | | | | | | | | | | | | | | | | | | | | | | | | | | | | | | | | | | | | | | | | | | | | | | | | | | | | | | | | | | | | | | | | | | | | | | | | | | | | | | | | | | | | | | | | | | | | | | | | | | | | | | | | | | | | | | | | | | | | | | | | | | | | | | | | | | | | | | | | | | | | | | | | | | | | | | | | | | | | | | | | | | | | | | | | | | | | | | | | | | | | | | | | | | | | | | | | | | | | | | | | | | | | | | | | | | | | | | | | | | | | | | | | | | | | | | | | | | | | | | | | | | | | | | | | | | | | | | | | | | | | | | | | | | | | | | | | | | | | | | | | | | | | | | | | | | | | | | | | | | | | | | | | | | | | | | | | | | | | | | | | | | | | | | | | | | | | | | | | | | | | | | | | | | | | | | | | | | | | | | | | | | | | | | | | | | | | | | | | | | | | | | | | | | | | | | | | | | | | | | | | | | | | | | | | | | | | | | | | | | | | | | | | | | | | | | | | | | | | | | | | | | | | | | | | | | | | | | | | | | | | | | | | | | | | | | | | | | | | | | | | | | | | | | | | | | | | | | | | | | | | | | | | | | | | | | | | | | | | | | | | | | | | | | | | | | | | | | | | | | | | | | | | | | | | | | | | | | | | | | | | | | | | | | | | | | | | | | | | | | | | | | | | | | | | | | | | | | | | | | | | | | | | | | | | | | | | | | | | | | | | | | | | | | | | | | | | | | | | | | | | | | | | | | | | | | | | | | | | | | | | | | | | | | | | | | | | | | | | | | | | | | | | | | | | | | | | | | | | | | | | | | | | | | | | | | | | | | | | | | | | | | | | | | | | | | | | | | | | | | | | | | | | | | | | | | | | | | | | | | |
| 640-20 n=4800 RO=0,005 | | | | | | | | | | | | | | | | | | | | | | | | | | | | | | | | | | | | | | | | | | | | | | | | | | | | | | | | | | | | | | | | | | | | | | | | | | | | | | | | | | | | | | | | | | | | | | | | | | | | | | | | | | | | | | | | | | | | | | | | | | | | | | | | | | | | | | | | | | | | | | | | | | | | | | | | | | | | | | | | | | | | | | | | | | | | | | | | | | | | | | | | | | | | | | | | | | | | | | | | | | | | | | | | | | | | | | | | | | | | | | | | | | | | | | | | | | | | | | | | | | | | | | | | | | | | | | | | | | | | | | | | | | | | | | | | | | | | | | | | | | | | | | | | | | | | | | | | | | | | | | | | | | | | | | | | | | | | | | | | | | | | | | | | | | | | | | | | | | | | | | | | | | | | | | | | | | | | | | | | | | | | | | | | | | | | | | | | | | | | | | | | | | | | | | | | | | | | | | | | | | | | | | | | | | | | | | | | | | | | | | | | | | | | | | | | | | | | | | | | | | | | | | | | | | | | | | | | | | | | | | | | | | | | | | | | | | | | | | | | | | | | | | | | | | | | | | | | | | | | | | | | | | | | | | | | | | | | | | | | | | | | | | | | | | | | | | | | | | | | | | | | | | | | | | | | | | | | | | | | | | | | | | | | | | | | | | | | | | | | | | | | | | | | | | | | | | | | | | | | | | | | | | | | | | | | | | | | | | | | | | | | | | | | | | | | | | | | | | | | | | | | | | | | | | | | | | | | | | | | | | | | | | | | | | | | | | | | | | | | | | | | | | | | | | | | | | | | | | | | | | | | | | | | | | | | | | | | | | | | | | | | | | | | | | | | | | | | | | | | | | | | | | | | | | | | | | | | | | | | | | | | | | | | | | | | | | | | | | | | | | | | | | | | | | | | | | | |
| 663 n=7000 R=0,005 | | | | | | | | | | | | | 6 | | | | | | | | | | | | | | | | | | | | | | | | | | | | | | | | | | | | | | | | | | | | | | | | | | | | | | | | | | | | | | | | | | | | | | | | | | | | | | | | | | | | | | | | | | | | | | | | | | | | | | | | | | | | | | | | | | | | | | | | | | | | | | | | | | | | | | | | | | | | | | | | | | | | | | | | | | | | | | | | | | | | | | | | | | | | | | | | | | | | | | | | | | | | | | | | | | | | | | | | | | | | | | | | | | | | | | | | | | | | | | | | | | | | | | | | | | | | | | | | | | | | | | | | | | | | | | | | | | | | | | | | | | | | | | | | | | | | | | | | | | | | | | | | | | | | | | | | | | | | | | | | | | | | | | | | | | | | | | | | | | | | | | | | | | | | | | | | | | | | | | | | | | | | | | | | | | | | | | | | | | | | | | | | | | | | | | | | | | | | | | | | | | | | | | | | | | | | | | | | | | | | | | | | | | | | | | | | | | | | | | | | | | | | | | | | | | | | | | | | | | | | | | | | | | | | | | | | | | | | | | | | | | | | | | | | | | | | | | | | | | | | | | | | | | | | | | | | | | | | | | | | | | | | | | | | | | | | | | | | | | | | | | | | | | | | | | | | | | | | | | | | | | | | | | | | | | | | | | | | | | | | | | | | | | | | | | | | | | | | | | | | | | | | | | | | | | | | | | | | | | | | | | | | | | | | | | | | | | | | | | | | | | | | | | | | | | | | | | | | | | | | | | | | | | | | | | | | | | | | | | | | | | | | | | | | | | | | | | | | | | | | | | | | | | | | | | | | | | | | | | | | | | | | | | | | | | | | | | | | | | | | | | | | | | | | | | | | | | | | | | | | | | | | | | | | | | | | | | | | | | | | | | | | | | | | | | | | | | | | | | |
| 640-80 n=4800 RO=0,005 | | | | | | | | | | | | | | | | | | | | | | | | | | | | | | | | | | | | | | | | | | | | | | | | | | | | | | | | | | | | | | | | | | | | | | | | | | | | | | | | | | | | | | | | | | | | | | | | | | | | | | | | | | | | | | | | | | | | | | | | | | | | | | | | | | | | | | | | | | | | | | | | | | | | | | | | | | | | | | | | | | | | | | | | | | | | | | | | | | | | | | | | | | | | | | | | | | | | | | | | | | | | | | | | | | | | | | | | | | | | | | | | | | | | | | | | | | | | | | | | | | | | | | | | | | | | | | | | | | | | | | | | | | | | | | | | | | | | | | | | | | | | | | | | | | | | | | | | | | | | | | | | | | | | | | | | | | | | | | | | | | | | | | | | | | | | | | | | | | | | | | | | | | | | | | | | | | | | | | | | | | | | | | | | | | | | | | | | | | | | | | | | | | | | | | | | | | | | | | | | | | | | | | | | | | | | | | | | | | | | | | | | | | | | | | | | | | | | | | | | | | | | | | | | | | | | | | | | | | | | | | | | | | | | | | | | | | | | | | | | | | | | | | | | | | | | | | | | | | | | | | | | | | | | | | | | | | | | | | | | | | | | | | | | | | | | | | | | | | | | | | | | | | | | | | | | | | | | | | | | | | | | | | | | | | | | | | | | | | | | | | | | | | | | | | | | | | | | | | | | | | | | | | | | | | | | | | | | | | | | | | | | | | | | | | | | | | | | | | | | | | | | | | | | | | | | | | | | | | | | | | | | | | | | | | | | | | | | | | | | | | | | | | | | | | | | | | | | | | | | | | | | | | | | | | | | | | | | | | | | | | | | | | | | | | | | | | | | | | | | | | | | | | | | | | | | | | | | | | | | | | | | | | | | | | | | | | | | | | | | | | | | | | | | | | | | | | | |
| 604 H n=3000 RO=0,02 | | | | | | | | | | | | | 6 | | | | | | | | | | | | | | | | | | | | | | | | | | | | | | | | | | | | | | | | | | | | | | | | | | | | | | | | | | | | | | | | | | | | | | | | | | | | | | | | | | | | | | | | | | | | | | | | | | | | | | | | | | | | | | | | | | | | | | | | | | | | | | | | | | | | | | | | | | | | | | | | | | | | | | | | | | | | | | | | | | | | | | | | | | | | | | | | | | | | | | | | | | | | | | | | | | | | | | | | | | | | | | | | | | | | | | | | | | | | | | | | | | | | | | | | | | | | | | | | | | | | | | | | | | | | | | | | | | | | | | | | | | | | | | | | | | | | | | | | | | | | | | | | | | | | | | | | | | | | | | | | | | | | | | | | | | | | | | | | | | | | | | | | | | | | | | | | | | | | | | | | | | | | | | | | | | | | | | | | | | | | | | | | | | | | | | | | | | | | | | | | | | | | | | | | | | | | | | | | | | | | | | | | | | | | | | | | | | | | | | | | | | | | | | | | | | | | | | | | | | | | | | | | | | | | | | | | | | | | | | | | | | | | | | | | | | | | | | | | | | | | | | | | | | | | | | | | | | | | | | | | | | | | | | | | | | | | | | | | | | | | | | | | | | | | | | | | | | | | | | | | | | | | | | | | | | | | | | | | | | | | | | | | | | | | | | | | | | | | | | | | | | | | | | | | | | | | | | | | | | | | | | | | | | | | | | | | | | | | | | | | | | | | | | | | | | | | | | | | | | | | | | | | | | | | | | | | | | | | | | | | | | | | | | | | | | | | | | | | | | | | | | | | | | | | | | | | | | | | | | | | | | | | | | | | | | | | | | | | | | | | | | | | | | | | | | | | | | | | | | | | | | | | | | | | | | | | | | | | | | | | | | | | | | | | | | | | | | | | | | |
| 604 H n=1500 RO=0,01 | | | | | | | | | | | | | | | | | | | | | | | | | | | | | | | | | | | | | | | | | | | | | | | | | | | | | | | | | | | | | | | | | | | | | | | | | | | | | | | | | | | | | | | | | | | | | | | | | | | | | | | | | | | | | | | | | | | | | | | | | | | | | | | | | | | | | | | | | | | | | | | | | | | | | | | | | | | | | | | | | | | | | | | | | | | | | | | | | | | | | | | | | | | | | | | | | | | | | | | | | | | | | | | | | | | | | | | | | | | | | | | | | | | | | | | | | | | | | | | | | | | | | | | | | | | | | | | | | | | | | | | | | | | | | | | | | | | | | | | | | | | | | | | | | | | | | | | | | | | | | | | | | | | | | | | | | | | | | | | | | | | | | | | | | | | | | | | | | | | | | | | | | | | | | | | | | | | | | | | | | | | | | | | | | | | | | | | | | | | | | | | | | | | | | | | | | | | | | | | | | | | | | | | | | | | | | | | | | | | | | | | | | | | | | | | | | | | | | | | | | | | | | | | | | | | | | | | | | | | | | | | | | | | | | | | | | | | | | | | | | | | | | | | | | | | | | | | | | | | | | | | | | | | | | | | | | | | | | | | | | | | | | | | | | | | | | | | | | | | | | | | | | | | | | | | | | | | | | | | | | | | | | | | | | | | | | | | | | | | | | | | | | | | | | | | | | | | | | | | | | | | | | | | | | | | | | | | | | | | | | | | | | | | | | | | | | | | | | | | | | | | | | | | | | | | | | | | | | | | | | | | | | | | | | | | | | | | | | | | | | | | | | | | | | | | | | | | | | | | | | | | | | | | | | | | | | | | | | | | | | | | | | | | | | | | | | | | | | | | | | | | | | | | | | | | | | | | | | | | | | | | | | | | | | | | | | | | | | | | | | | | | | | | | | | | | | | | |
| 604 H n=2600 RO=0,01 | | | | | | | | | | | | | 6 | | | | | | | | | | | | | | | | | | | | | | | | | | | | | | | | | | | | | | | | | | | | | | | | | | | | | | | | | | | | | | | | | | | | | | | | | | | | | | | | | | | | | | | | | | | | | | | | | | | | | | | | | | | | | | | | | | | | | | | | | | | | | | | | | | | | | | | | | | | | | | | | | | | | | | | | | | | | | | | | | | | | | | | | | | | | | | | | | | | | | | | | | | | | | | | | | | | | | | | | | | | | | | | | | | | | | | | | | | | | | | | | | | | | | | | | | | | | | | | | | | | | | | | | | | | | | | | | | | | | | | | | | | | | | | | | | | | | | | | | | | | | | | | | | | | | | | | | | | | | | | | | | | | | | | | | | | | | | | | | | | | | | | | | | | | | | | | | | | | | | | | | | | | | | | | | | | | | | | | | | | | | | | | | | | | | | | | | | | | | | | | | | | | | | | | | | | | | | | | | | | | | | | | | | | | | | | | | | | | | | | | | | | | | | | | | | | | | | | | | | | | | | | | | | | | | | | | | | | | | | | | | | | | | | | | | | | | | | | | | | | | | | | | | | | | | | | | | | | | | | | | | | | | | | | | | | | | | | | | | | | | | | | | | | | | | | | | | | | | | | | | | | | | | | | | | | | | | | | | | | | | | | | | | | | | | | | | | | | | | | | | | | | | | | | | | | | | | | | | | | | | | | | | | | | | | | | | | | | | | | | | | | | | | | | | | | | | | | | | | | | | | | | | | | | | | | | | | | | | | | | | | | | | | | | | | | | | | | | | | | | | | | | | | | | | | | | | | | | | | | | | | | | | | | | | | | | | | | | | | | | | | | | | | | | | | | | | | | | | | | | | | | | | | | | | | | | | | | | | | | | | | | | | | | | | | | | | | | | | | | | |
| 604 HG n=2600 RO=0,01 | | | | | | | | | | | | | | | | | | | | | | | | | | | | | | | | | | | | | | | | | | | | | | | | | | | | | | | | | | | | | | | | | | | | | | | | | | | | | | | | | | | | | | | | | | | | | | | | | | | | | | | | | | | | | | | | | | | | | | | | | | | | | | | | | | | | | | | | | | | | | | | | | | | | | | | | | | | | | | | | | | | | | | | | | | | | | | | | | | | | | | | | | | | | | | | | | | | | | | | | | | | | | | | | | | | | | | | | | | | | | | | | | | | | | | | | | | | | | | | | | | | | | | | | | | | | | | | | | | | | | | | | | | | | | | | | | | | | | | | | | | | | | | | | | | | | | | | | | | | | | | | | | | | | | | | | | | | | | | | | | | | | | | | | | | | | | | | | | | | | | | | | | | | | | | | | | | | | | | | | | | | | | | | | | | | | | | | | | | | | | | | | | | | | | | | | | | | | | | | | | | | | | | | | | | | | | | | | | | | | | | | | | | | | | | | | | | | | | | | | | | | | | | | | | | | | | | | | | | | | | | | | | | | | | | | | | | | | | | | | | | | | | | | | | | | | | | | | | | | | | | | | | | | | | | | | | | | | | | | | | | | | | | | | | | | | | | | | | | | | | | | | | | | | | | | | | | | | | | | | | | | | | | | | | | | | | | | | | | | | | | | | | | | | | | | | | | | | | | | | | | | | | | | | | | | | | | | | | | | | | | | | | | | | | | | | | | | | | | | | | | | | | | | | | | | | | | | | | | | | | | | | | | | | | | | | | | | | | | | | | | | | | | | | | | | | | | | | | | | | | | | | | | | | | | | | | | | | | | | | | | | | | | | | | | | | | | | | | | | | | | | | | | | | | | | | | | | | | | | | | | | | | | | | | | | | | | | | | | | | | | | | | | | | | | | | | | | |

Technical features MKS

Advantages:

- Different models suitable to various applications
- Body hardened and ground
- Live centre hardened, repeated regrinding at will
- Triple bearing method
- High runout accuracy
- Life-time lubricated
- High speeds
- Heavy duty
- Long life

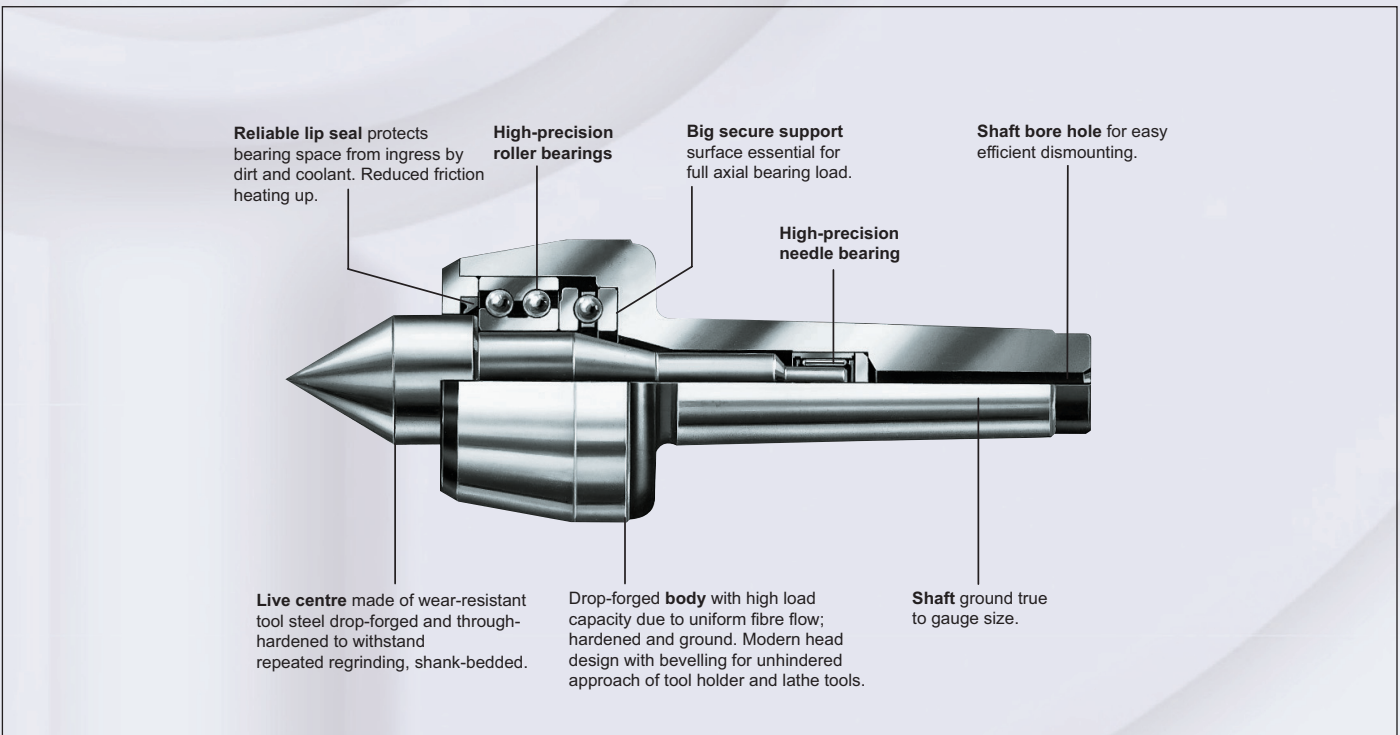
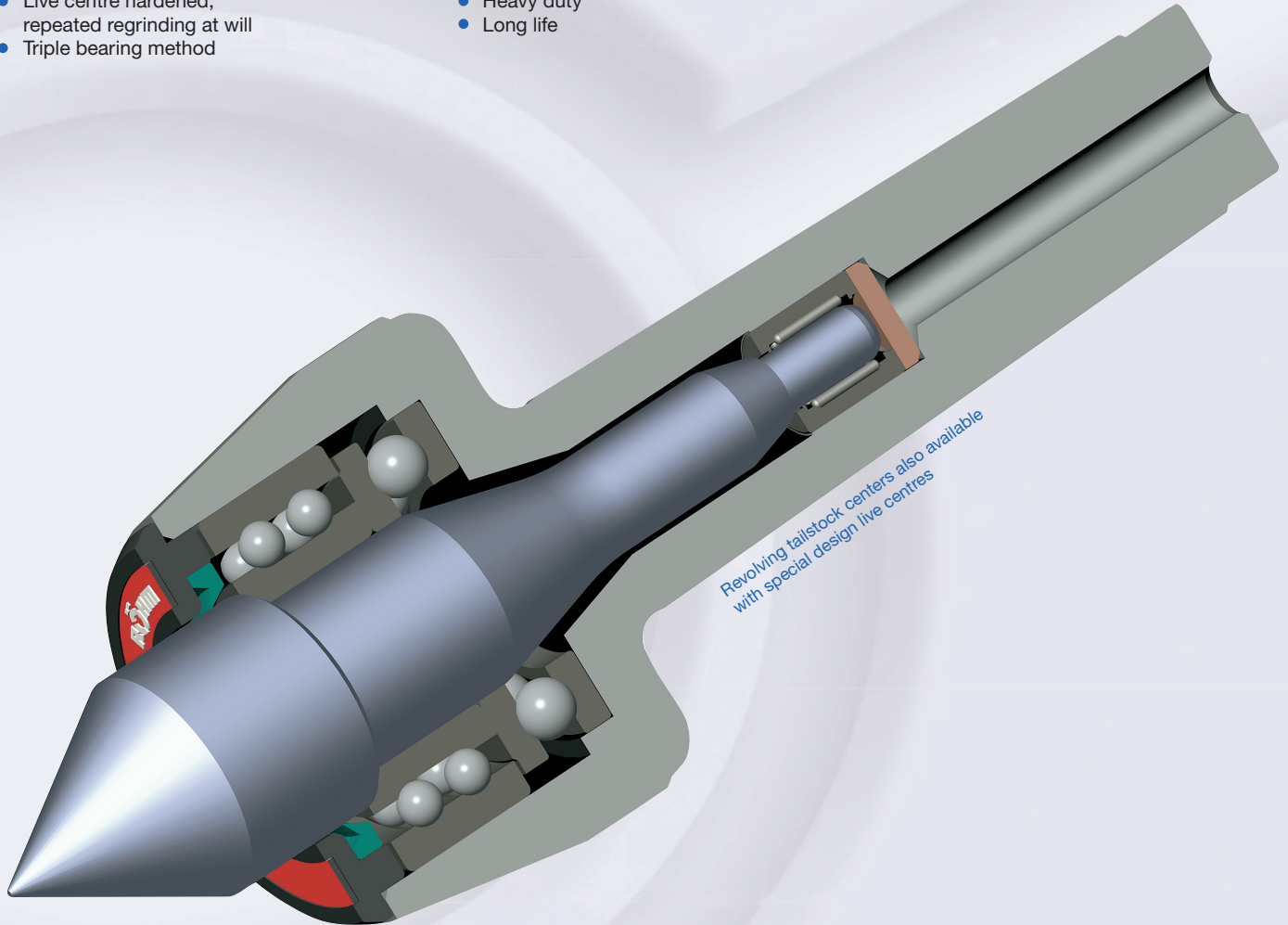

MKS - Tip angle 60°

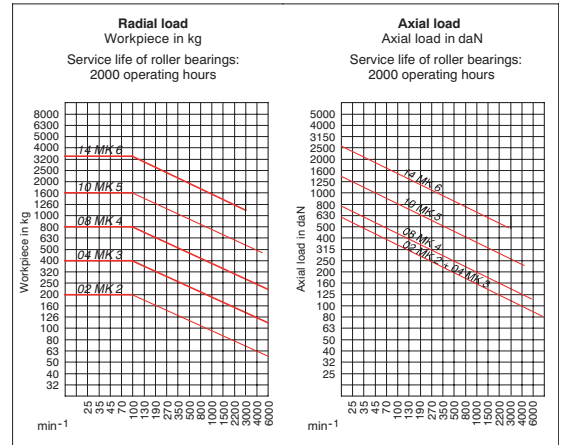
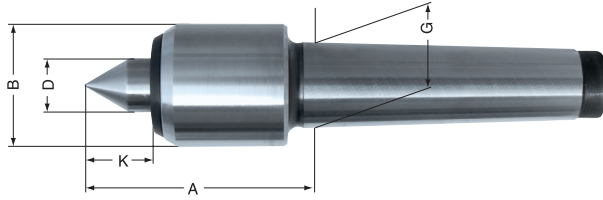

Tool group A06
Type 600
with **small casing diameter**

| Item no. | 005336 ● | 005429 ● | 005469 ● | 005490 ● | 005547 ● |
|------------------------------|----------|----------|----------|----------|----------|
| Mount MT | 2 | 3 | 4 | 5 | 6 |
| Size | 02 | 04 | 08 | 10 | 14 |
| A | 62 | 62 | 75,5 | 104 | 143 |
| B | 32 | 34 | 42 | 58 | 80 |
| D | 15 | 15 | 20 | 30 | 42 |
| G | 17,78 | 23,825 | 31,267 | 44,399 | 63,348 |
| K | 18 | 18 | 25 | 34 | 49 |
| Weight approx. g | 300 | 400 | 1000 | 2600 | 7100 |
| Workpiece weight max. kg | 200 | 400 | 800 | 1600 | 3500 |
| Concentricity deviation | 0,005 | 0,005 | 0,005 | 0,01 | 0,02 |
| Speed max. min ⁻¹ | 7000 | 7000 | 6300 | 4300 | 3000 |
| Spare live centres | 005339 | 005432 | 005472 | 005493 | 005550 |

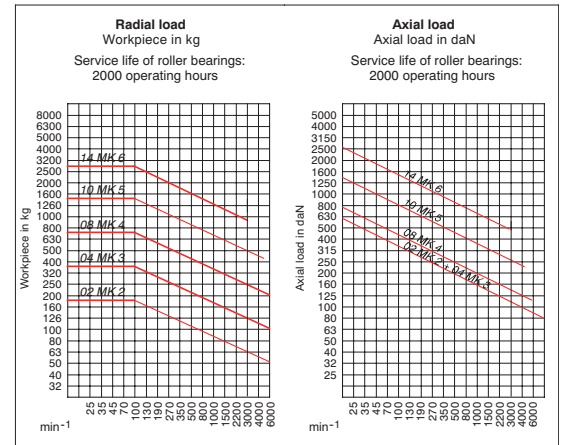
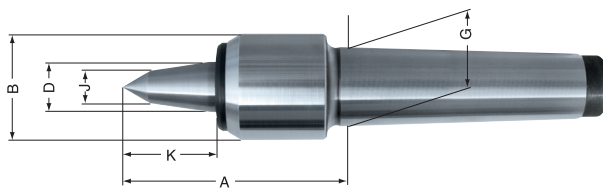

Tool group A06
Type 600-20
with **extended live centre**

| Item no. | 362080 ● | 362081 ● | 362082 ● | 362083 ● | 362084 ● |
|------------------------------|----------|----------|----------|----------|----------|
| Mount MT | 2 | 3 | 4 | 5 | 6 |
| Size | 02 | 04 | 08 | 10 | 14 |
| A | 73 | 74 | 88,5 | 119 | 164 |
| B | 32 | 34 | 42 | 58 | 80 |
| D | 15 | 15 | 20 | 30 | 42 |
| G | 17,78 | 23,825 | 31,267 | 44,399 | 63,348 |
| K | 29 | 30 | 38 | 49 | 70 |
| J | 10 | 11 | 13 | 14 | 18 |
| Weight approx. g | 320 | 460 | 1000 | 2600 | 7100 |
| Workpiece weight max. kg | 170 | 340 | 700 | 1400 | 3000 |
| Concentricity deviation | 0,008 | 0,008 | 0,008 | 0,01 | 0,02 |
| Speed max. min ⁻¹ | 7000 | 7000 | 6300 | 4300 | 3000 |
| Spare live centres | 362085 | 362086 | 362087 | 362088 | 362089 |

MKS - Tip angle 60°

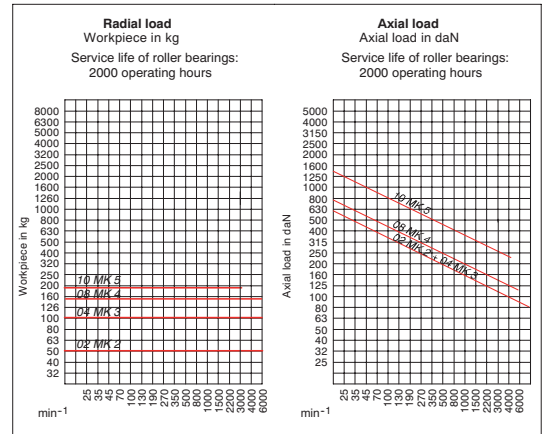
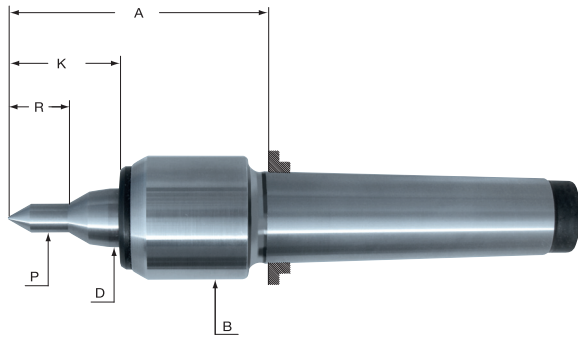

Tool group A06
Type 600-20
with **profiled centre point**

| Item no. | 552606 ● | 552607 ● | 552608 ● | 552609 ● |
|------------------------------|----------|----------|----------|----------|
| Mount MT | 2 | 3 | 4 | 5 |
| Size | 02 | 04 | 08 | 10 |
| A | 73 | 74 | 88,5 | 119 |
| B | 32 | 34 | 42 | 58 |
| D | 15 | 15 | 20 | 30 |
| K | 29 | 30 | 38 | 49 |
| P | 6 | 8 | 10 | 12 |
| R | 12 | 16 | 20 | 26 |
| Workpiece weight max. kg | 50 | 100 | 150 | 180 |
| Speed max. min ⁻¹ | 7000 | 7000 | 6300 | 4300 |
| Spare live centres | 552814 | 552815 | 552755 | 552816 |

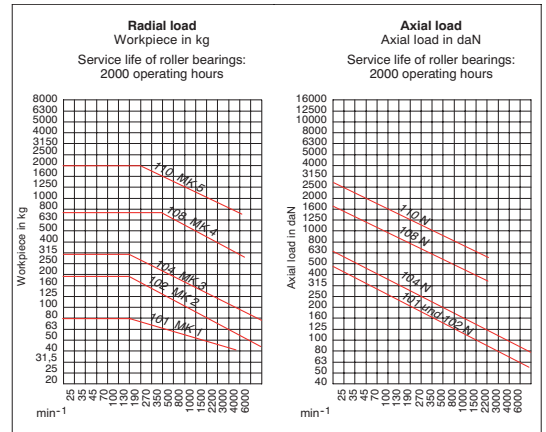
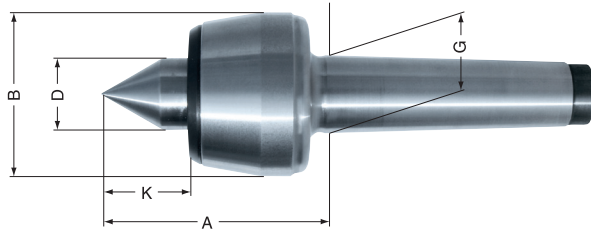

Tool group A06
Type 601 N **standard design**,
body only ground

| Item no. | 061740 ● | 043395 ● | 043111 ● | 042310 ● | 042171 ● | 042839 ● |
|------------------------------|----------|----------|----------|----------|----------|----------|
| Mount MT | 0 | 1 | 2 | 3 | 4 | 5 |
| Size | 100 | 101 | 102 | 104 | 108 | 110 |
| A | 44 | 60,5 | 65 | 70,5 | 102,5 | 129 |
| B | 25 | 36 | 45 | 50 | 70 | 90 |
| D | 10 | 15 | 20 | 22 | 32 | 40 |
| G | 9,045 | 12,065 | 17,78 | 23,825 | 31,267 | 44,399 |
| K | 11 | 17 | 24 | 27,5 | 41 | 50,5 |
| Weight approx. g | 200 | 400 | 500 | 800 | 2300 | 4700 |
| Workpiece weight max. kg | 10 | 80 | 180 | 300 | 750 | 1800 |
| Concentricity deviation | 0,01 | 0,005 | 0,005 | 0,005 | 0,005 | 0,005 |
| Speed max. min ⁻¹ | 15000 | 7000 | 7000 | 6300 | 3800 | 3000 |
| Spare live centres | 005660 | 043398 | 005728 | 005780 | 005796 | 005806 |

MKS - Tip angle 60°

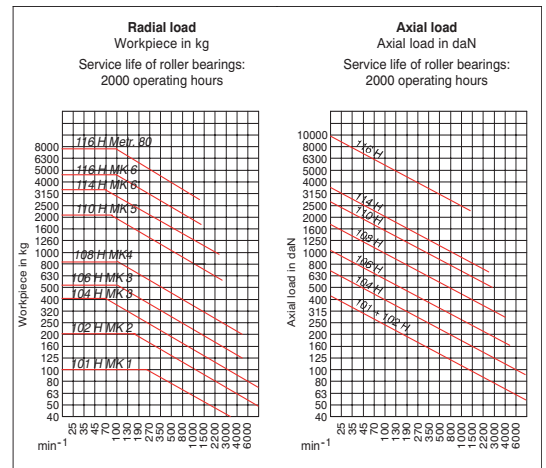
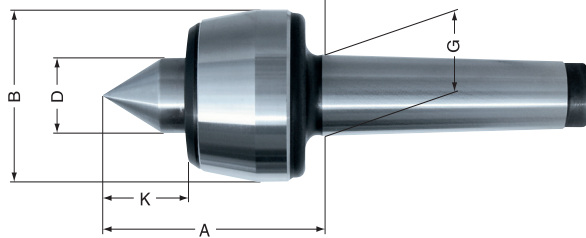

Tool group A06
Type 604 H
body hardened and ground

| Item no. | 043400 ● | 043115 ● | 042315 ● | 042776 ● | 042175 ● | 042843 ● | 043532 ● | 093439 ● | 093440 ● |
|------------------------------|----------|----------|----------|----------|----------|----------|----------|----------|----------|
| Mount MT | 1 | 2 | 3 | 3 | 4 | 5 | 6 | MK 6 | Metr. 80 |
| Size | 101 | 102 | 104 | 106 | 108 | 110 | 114 | 116 | 116 |
| A | 60,5 | 65 | 70,5 | 79,5 | 102,5 | 129 | 152 | 196 | 196 |
| B | 36 | 45 | 50 | 60 | 70 | 90 | 105 | 140 | 140 |
| D | 15 | 20 | 22 | 25 | 32 | 40 | 50 | 60 | 60 |
| G | 12,065 | 17,78 | 23,825 | 23,825 | 31,267 | 44,399 | 63,348 | 63,348 | 80 |
| K | 17 | 24 | 27,5 | 31 | 41 | 50,5 | 57,5 | 67 | 68 |
| Weight approx. g | 400 | 500 | 800 | 1300 | 2300 | 4700 | 10200 | 17800 | 23000 |
| Workpiece weight max. kg | 100 | 200 | 400 | 500 | 800 | 2000 | 3500 | 5000 | 8500 |
| Concentricity deviation | 0,005 | 0,005 | 0,005 | 0,005 | 0,005 | 0,005 | 0,01 | 0,01 | 0,015 |
| Speed max. min ⁻¹ | 7000 | 7000 | 6300 | 5000 | 3800 | 3000 | 2600 | 1500 | 1500 |
| Spare live centres | 043398 | 005728 | 005780 | 005896 | 005796 | 005806 | 005911 | 093458 | 093464 |

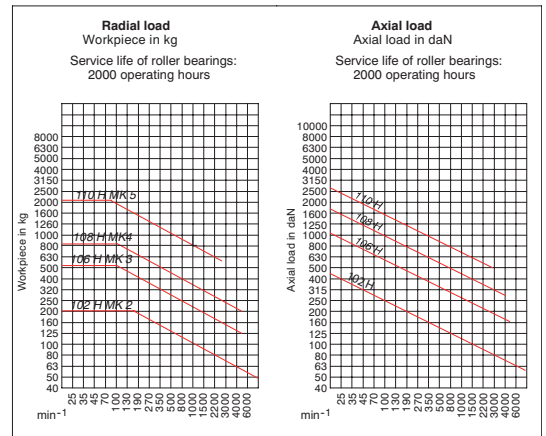
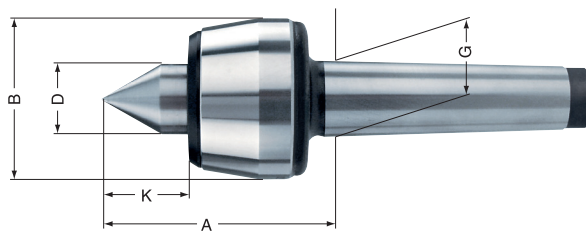

Tool group A06
Type 604 HP
precision version

| Item no. | 082392 ● | 318227 ● | 082394 ● | 082395 ● |
|------------------------------|----------|----------|----------|----------|
| Mount MT | 2 | 3 | 4 | 5 |
| Size | 102 | 106 | 108 | 110 |
| A | 65 | 82 | 102,5 | 129 |
| B | 45 | 55 | 70 | 90 |
| D | 20 | 25 | 32 | 40 |
| G | 17,78 | 23,825 | 31,267 | 44,399 |
| K | 24 | 30,5 | 41 | 50,5 |
| Weight approx. g | 500 | 1300 | 2300 | 4700 |
| Workpiece weight max. kg | 200 | 500 | 800 | 2000 |
| Concentricity deviation | 0,003 | 0,003 | 0,003 | 0,003 |
| Speed max. min ⁻¹ | 7000 | 5000 | 3800 | 3000 |
| Spare live centres | 005728 | 324478 | 005796 | 005806 |

MKS - Tip angle 60°

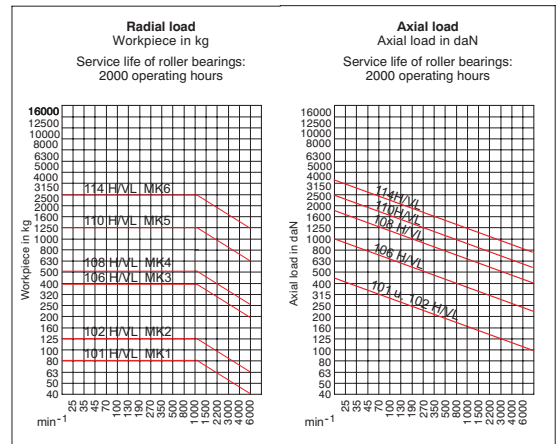
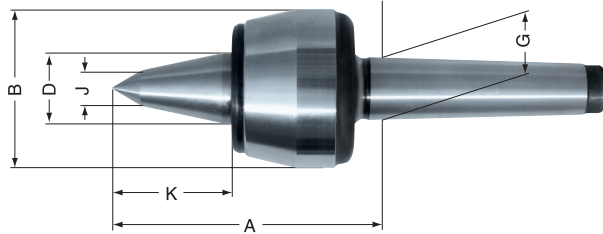

Tool group A06
Type 604 HVL
with **extended live centre**

| Item no. | 058668 ● | 058669 ● | 058670 ● | 058671 ● | 058672 ● | 058673 ● |
|------------------------------|----------|----------|----------|----------|----------|----------|
| Mount MT | 1 | 2 | 3 | 4 | 5 | 6 |
| Size | 101 | 102 | 106 | 108 | 110 | 114 |
| A | 70,5 | 75 | 95,5 | 114,5 | 143,5 | 172,5 |
| B | 36 | 45 | 60 | 70 | 90 | 105 |
| D | 15 | 20 | 25 | 32 | 40 | 50 |
| G | 12,065 | 17,78 | 23,825 | 31,267 | 44,399 | 63,348 |
| K | 27 | 34 | 47 | 53 | 65 | 78 |
| J | 9 | 10 | 12 | 14 | 16 | 18 |
| Weight approx. g | 400 | 500 | 1300 | 2300 | 4800 | 10200 |
| Workpiece weight max. kg | 80 | 140 | 400 | 500 | 1200 | 2500 |
| Concentricity deviation | 0,01 | 0,005 | 0,005 | 0,005 | 0,005 | 0,01 |
| Speed max. min ⁻¹ | 7000 | 7000 | 5000 | 3800 | 3000 | 2600 |
| Spare live centres | 068722 | 068723 | 068724 | 068725 | 068727 | 068728 |

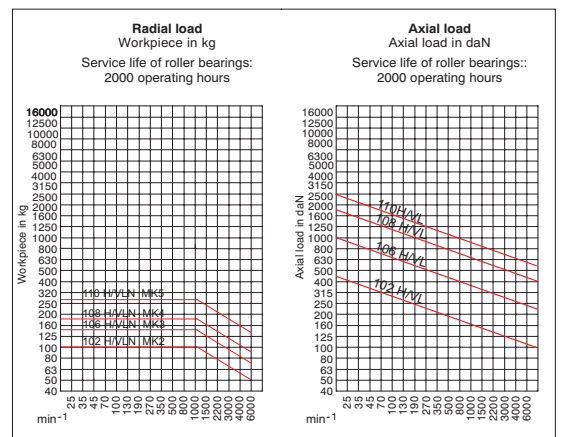
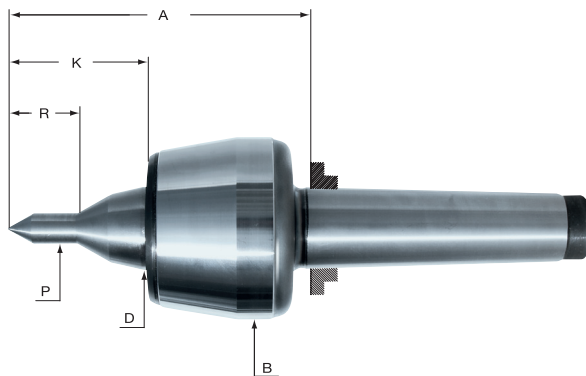

Tool group A06
Type 604 HVLN
with **profiled centre point**

| Item no. | 552629 ■ | 552630 ■ | 552631 ■ | 552632 ■ |
|------------------------------|----------|----------|----------|----------|
| Mount MT | 2 | 3 | 4 | 5 |
| Size | 102 | 106 | 108 | 110 |
| A | 75 | 95,5 | 114,5 | 143,5 |
| B | 45 | 60 | 70 | 90 |
| D | 20 | 25 | 32 | 40 |
| K | 34 | 47 | 53 | 65 |
| P | 8 | 10 | 12 | 14 |
| R | 16 | 20 | 26 | 30 |
| Workpiece weight max. kg | 100 | 150 | 180 | 280 |
| Speed max. min ⁻¹ | 7000 | 5000 | 3800 | 3000 |
| Spare live centres | 552817 | 552818 | 552792 | 552819 |

MKS - Tip angle 60°

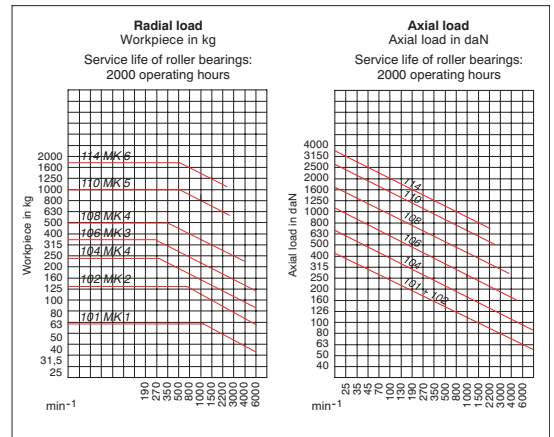
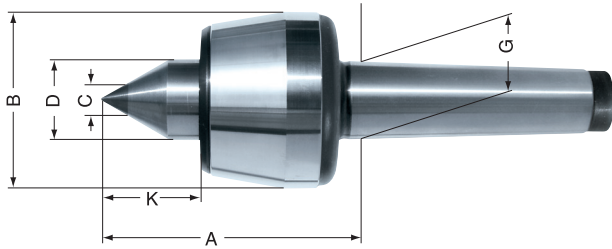

Tool group A06
Type 604 HM
with **carbide insert**

| Item no. | 225297 | 032140 | 090089 | 237413 | 093306 | 221016 | 221017 |
|------------------------------|--------|--------|--------|--------|--------|--------|--------|
| Mount MT | 1 | 2 | 3 | 3 | 4 | 5 | 6 |
| Size | 101 | 102 | 104 | 106 | 108 | 110 | 114 |
| A | 60,5 | 65 | 70,5 | 79,5 | 102,5 | 129 | 152 |
| B | 36 | 45 | 50 | 60 | 70 | 90 | 105 |
| C | 7 | 11 | 11 | 14 | 14 | 18 | 18 |
| D | 15 | 20 | 22 | 25 | 32 | 40 | 50 |
| G | 12,065 | 17,78 | 23,825 | 23,825 | 31,267 | 44,399 | 63,348 |
| K | 17 | 24 | 27,5 | 31 | 41 | 50,5 | 57,5 |
| Weight approx. g | 400 | 600 | 900 | 1300 | 2300 | 4700 | 10000 |
| Workpiece weight max. kg | 60 | 120 | 240 | 360 | 500 | 1000 | 1800 |
| Concentricity deviation | 0,005 | 0,005 | 0,005 | 0,005 | 0,005 | 0,005 | 0,01 |
| Speed max. min ⁻¹ | 7000 | 7000 | 6300 | 5000 | 3800 | 3000 | 2600 |
| Spare live centres | 097545 | 032141 | 090090 | 090330 | 090214 | 221033 | 221034 |

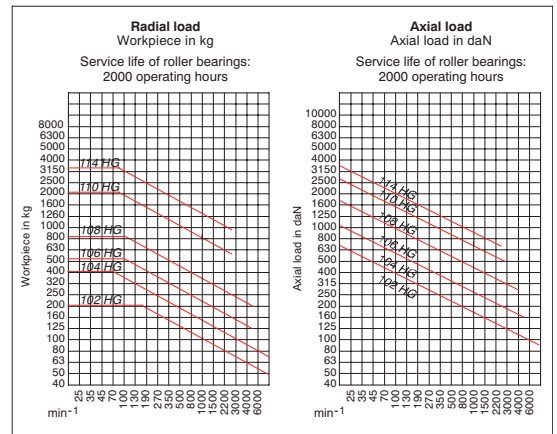
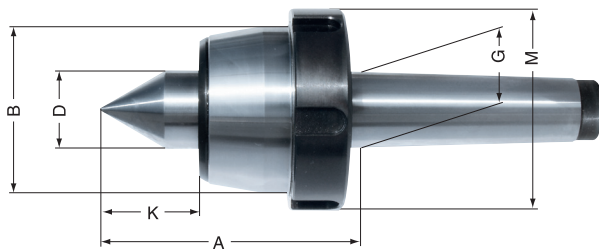

Tool group A06
Type 604 HG
with **draw-off nut**

| Item no. | 221018 | 221019 | 205036 | 207148 | 074390 | 221020 |
|------------------------------|--------|--------|--------|--------|--------|--------|
| Mount MT | 2 | 3 | 3 | 4 | 5 | 6 |
| Size | 102 | 104 | 106 | 108 | 110 | 114 |
| A | 65 | 70,5 | 79,5 | 102,5 | 129 | 152 |
| B | 45 | 50 | 60 | 70 | 90 | 105 |
| D | 20 | 22 | 25 | 32 | 40 | 50 |
| G | 17,78 | 23,825 | 23,825 | 31,267 | 44,399 | 63,348 |
| K | 24 | 27,5 | 31 | 41 | 50,5 | 57,5 |
| M | 56 | 62 | 74 | 82 | 105 | 120 |
| Weight approx. g | 600 | 1000 | 1400 | 2400 | 5200 | 10500 |
| Workpiece weight max. kg | 200 | 400 | 500 | 800 | 2000 | 3500 |
| Concentricity deviation | 0,005 | 0,005 | 0,005 | 0,005 | 0,005 | 0,01 |
| Speed max. min ⁻¹ | 7000 | 6300 | 5000 | 3800 | 3000 | 2600 |
| Spare live centres | 005728 | 005780 | 005896 | 005796 | 005806 | 005911 |

MKS - Tip angle 60°

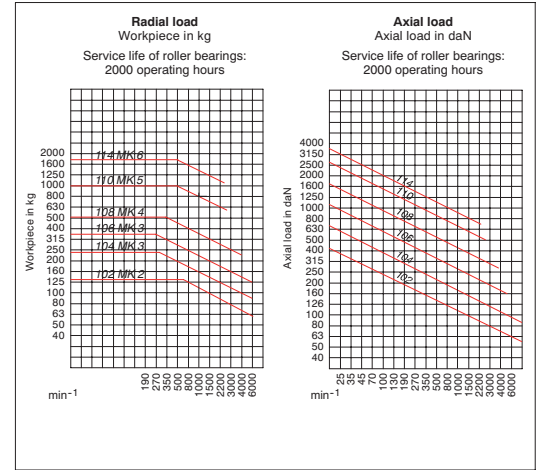
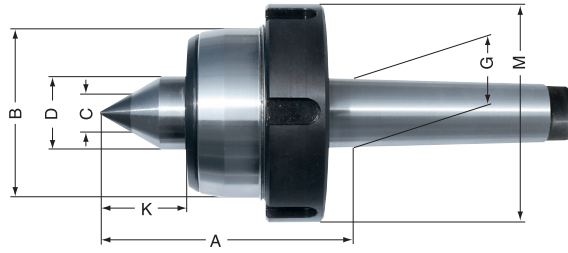

Tool group A06
Type 604 HMG
with draw-off nut and carbide insert

| Item no. | 221021 | 221022 | 221023 | 221024 | 221025 | 221026 |
|------------------------------|--------|--------|--------|--------|--------|--------|
| Mount MT | 2 | 3 | 3 | 4 | 5 | 6 |
| Size | 102 | 104 | 106 | 108 | 110 | 114 |
| A | 65 | 70,5 | 79,5 | 102,5 | 129 | 152 |
| B | 45 | 50 | 60 | 70 | 90 | 105 |
| C | 11 | 11 | 14 | 14 | 18 | 18 |
| D | 20 | 22 | 25 | 32 | 40 | 50 |
| G | 17,78 | 23,825 | 23,825 | 31,265 | 44,399 | 63,348 |
| K | 24 | 27,5 | 31 | 41 | 50,5 | 57,5 |
| M | 56 | 62 | 74 | 82 | 105 | 120 |
| Weight approx. g | 600 | 1000 | 1400 | 2400 | 5200 | 10500 |
| Workpiece weight max. kg | 120 | 240 | 360 | 500 | 1000 | 1800 |
| Concentricity deviation | 0,005 | 0,005 | 0,005 | 0,005 | 0,005 | 0,01 |
| Speed max. min ⁻¹ | 7000 | 6300 | 5000 | 3800 | 3000 | 2600 |
| Spare live centres | 032141 | 090090 | 090330 | 090214 | 221033 | 221034 |

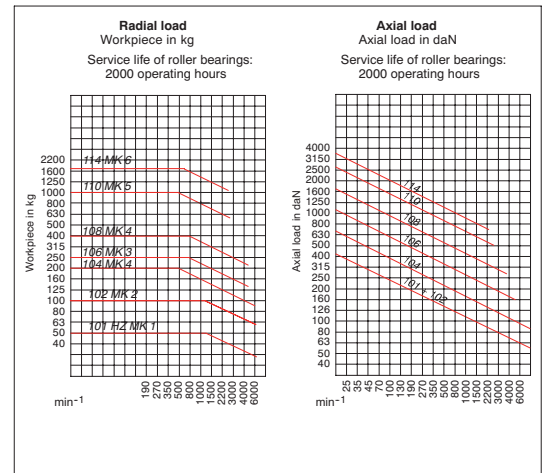
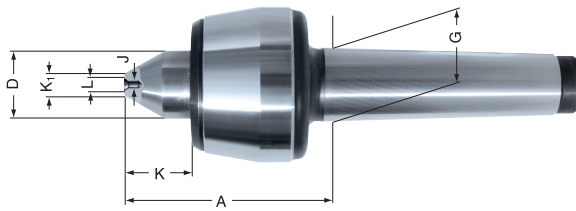

Tool group A06
Type 624 HZ with centre bore

| Item no. | 221260 | 221261 | 221262 | 221263 | 221264 | 221265 | 221266 |
|------------------------------|--------|--------|--------|--------|--------|--------|--------|
| Mount MT | 1 | 2 | 3 | 3 | 4 | 5 | 6 |
| Size | 101 | 102 | 104 | 106 | 108 | 110 | 114 |
| A | 56,5 | 60 | 65 | 72 | 92 | 115 | 135 |
| D | 15 | 20 | 22 | 25 | 32 | 40 | 50 |
| G | 12,065 | 17,78 | 23,825 | 23,825 | 31,267 | 44,399 | 63,348 |
| J | 1 | 1,5 | 2 | 2,5 | 3,15 | 5 | 6,3 |
| K | 13 | 19 | 21,5 | 23,5 | 30 | 36 | 40,5 |
| K1 | 5 | 6 | 7 | 9 | 12 | 16 | 20 |
| L | 3 | 4 | 5 | 6,5 | 8 | 12 | 16 |
| Weight approx. g | 400 | 500 | 900 | 1300 | 2300 | 4700 | 10000 |
| Workpiece weight max. kg | 50 | 100 | 200 | 250 | 400 | 1000 | 1700 |
| Concentricity deviation | 0,005 | 0,005 | 0,005 | 0,005 | 0,005 | 0,005 | 0,01 |
| Speed max. min ⁻¹ | 7000 | 7000 | 6300 | 5000 | 3800 | 3000 | 2600 |
| Spare live centres | 221267 | 221268 | 221269 | 221270 | 221271 | 221272 | 221273 |

MKS - Tip angle 60°

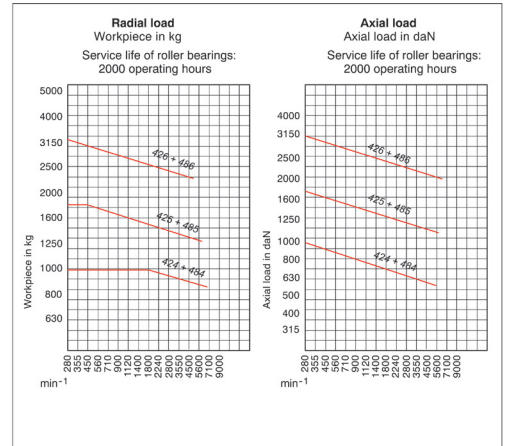
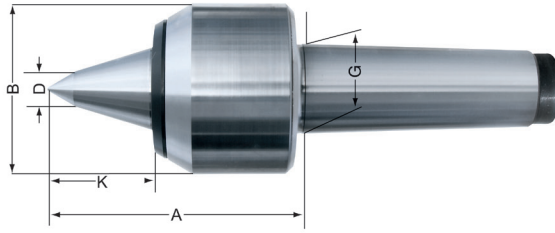

Tool group A06
Type 640-20
for **high load** at high speeds

| Item no. | 303598 ● | 303599 ● | 301696 ▲ |
|------------------------------|---------------|---------------|---------------|
| Mount MT | 4 | 5 | 6 |
| Size | 424 | 425 | 426 |
| A | 122 | 150 | 180 |
| B | 70 | 95 | 120 |
| D | 16 | 20 | 26 |
| G | 31,267 | 44,399 | 63,348 |
| K | 44 | 59 | 77 |
| Weight approx. g | 2600 | 5500 | 11500 |
| Workpiece weight max. kg | 1000 | 2000 | 3000 |
| Concentricity deviation | 0,005 | 0,005 | 0,005 |
| Speed max. min ⁻¹ | 7000 | 6000 | 4800 |
| Spare live centres | 306202 | 306182 | 301978 |

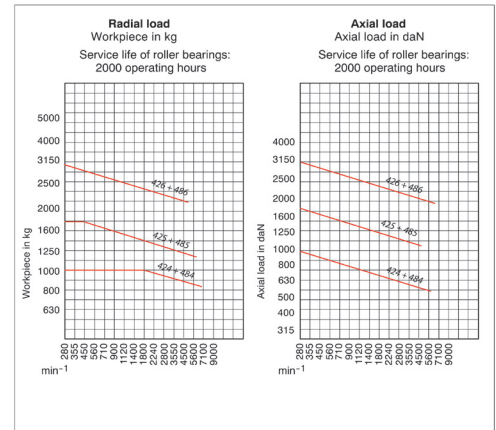
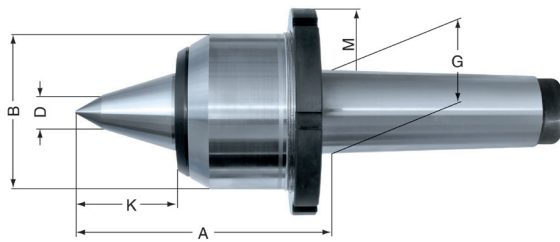

Tool group A06
Type 640-80
with **draw-off nut**

| Item no. | 304521 ● | 304522 ● | 304523 ● |
|------------------------------|---------------|---------------|---------------|
| Mount MT | 4 | 5 | 6 |
| Size | 484 | 485 | 486 |
| A | 122 | 150 | 180 |
| B | 70 | 95 | 120 |
| D | 16 | 20 | 26 |
| G | 31,267 | 44,399 | 63,348 |
| K | 44 | 59 | 77 |
| M | 100 | 125 | 155 |
| Weight approx. g | 2800 | 5400 | 12300 |
| Workpiece weight max. kg | 1000 | 2000 | 3000 |
| Concentricity deviation | 0,005 | 0,005 | 0,005 |
| Speed max. min ⁻¹ | 7000 | 6000 | 4800 |
| Spare live centres | 306202 | 306182 | 301978 |

MKS - Tip angle 60°

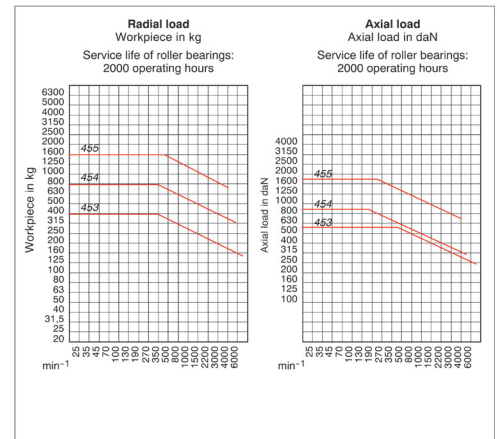
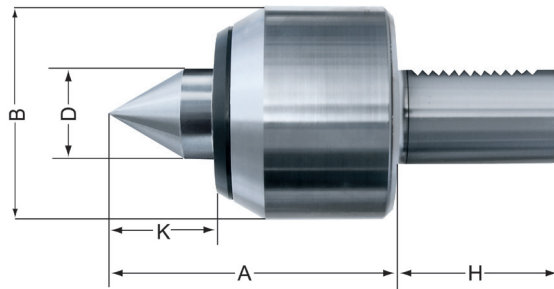

Tool group A06
Type 645-00
with shank VDI 3425/DIN 69880
live center spring-loaded

| Item no. | 664630 ■ | 664631 ■ | 664632 ▲ |
|------------------------------|----------|----------|----------|
| Shank-Ø | 30 | 40 | 50 |
| Size | 453 | 454 | 455 |
| A | 90 | 102 | 135 |
| B | 68 | 83 | 98 |
| D | 25 | 32 | 40 |
| H | 55 | 63 | 78 |
| K | 31,5 | 39 | 49 |
| Weight approx. g | 2200 | 3600 | 8400 |
| Spring way ¹⁾ | 1,7 | 2 | 2,2 |
| Axial load max. | 580 | 900 | 1800 |
| Workpiece weight max. kg | 400 | 800 | 1600 |
| Concentricity deviation | 0,01 | 0,01 | 0,01 |
| Speed max. min ⁻¹ | 7000 | 5500 | 4000 |

¹⁾ at max. axial load

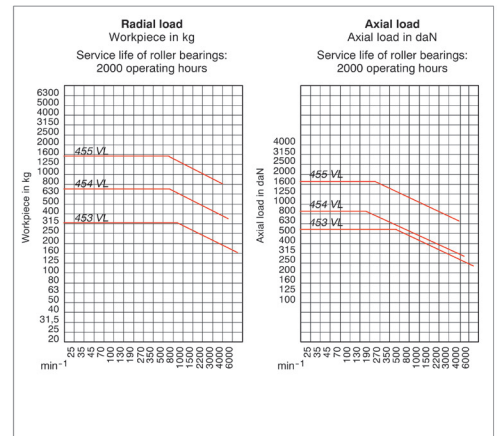
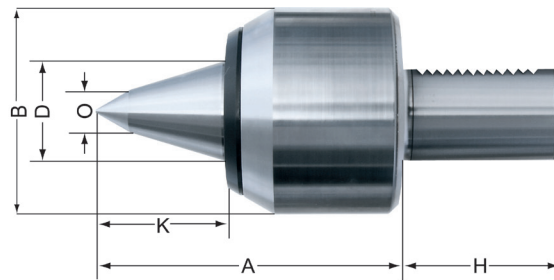

Tool group A06
Type 645-20
with shank VDI 3425/DIN 69880
with extended and spring-loaded
live centre

| Item no. | 664633 ■ | 664634 ■ | 664635 ▲ |
|------------------------------|----------|----------|----------|
| Shank-Ø | 30 | 40 | 50 |
| Size | 453 | 454 | 455 |
| A | 105 | 116 | 152 |
| B | 68 | 83 | 98 |
| D | 25 | 32 | 40 |
| H | 55 | 63 | 78 |
| O | 11 | 14 | 15 |
| K | 46,5 | 53 | 66 |
| Weight approx. g | 2300 | 3700 | 8500 |
| Spring way ¹⁾ | 1,7 | 2 | 2,2 |
| Axial load max. | 580 | 900 | 1800 |
| Workpiece weight max. kg | 300 | 650 | 1400 |
| Concentricity deviation | 0,01 | 0,01 | 0,01 |
| Speed max. min ⁻¹ | 7000 | 5500 | 4000 |

¹⁾ at max. axial load

MKS - Tip angle 60°

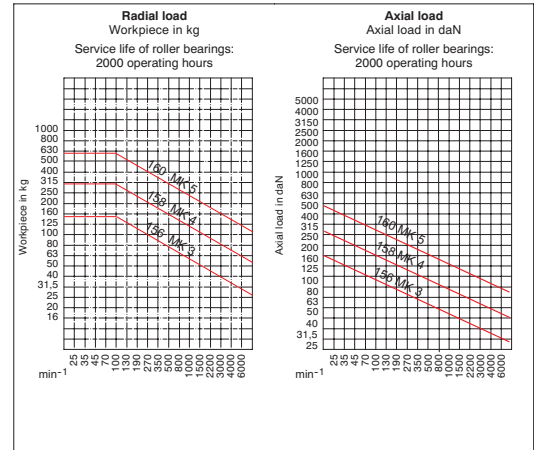
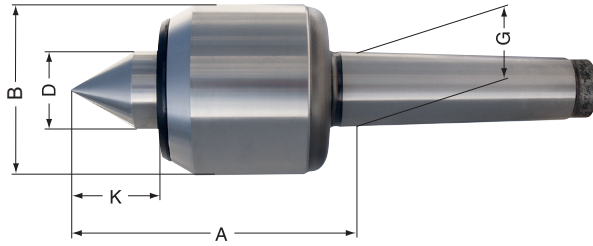

Tool group A06
Type 615
with **impact damping**

| Item no. | 060779 ● | 060846 ● | 060881 ● |
|------------------------------|----------|----------|----------|
| Mount MT | 3 | 4 | 5 |
| Size | 156 | 158 | 160 |
| A | 97 | 113,5 | 148 |
| B | 60 | 70 | 95 |
| D | 25 | 32 | 40 |
| G | 23,825 | 31,267 | 44,399 |
| K | 31,5 | 39,5 | 49,5 |
| Weight approx. g | 1500 | 2500 | 7100 |
| Workpiece weight max. kg | 150 | 300 | 600 |
| Concentricity deviation | 0,01 | 0,01 | 0,01 |
| Speed max. min ⁻¹ | 8000 | 7000 | 5000 |
| Spare live centres | 009841 | 010175 | 012677 |

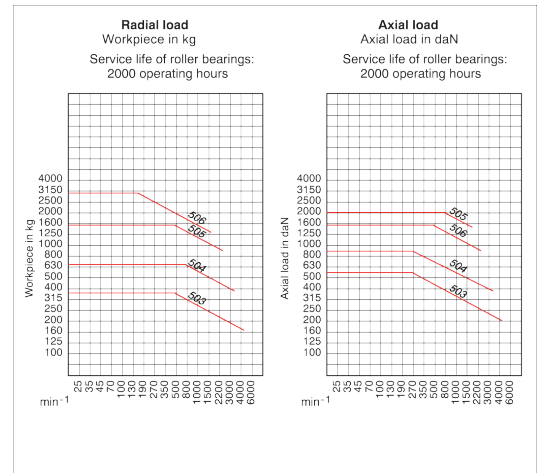
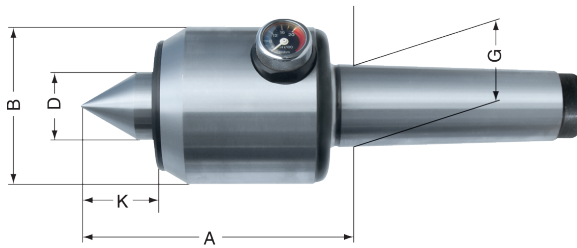

Tool group A06
Type 652 AC
with **pressure display**
and **length compensation**
as counter centre with face drivers

| Item no. | 060798 ● | 060874 ● | 060906 ● | 060915 ● |
|------------------------------|----------|----------|----------|----------|
| Mount MT | 3 | 4 | 5 | 6 |
| Size | 503 | 504 | 505 | 506 |
| A | 105 | 123,5 | 160,5 | 202 |
| B | 64 | 72 | 95 | 120 |
| D | 25 | 32 | 40 | 52 |
| G | 23,825 | 31,267 | 44,399 | 63,348 |
| K | 31,5 | 39 | 49 | 59 |
| Weight approx. g | 2100 | 3500 | 8300 | 17000 |
| Spring way ¹⁾ | 1,6 | 2 | 1,8 | 2,7 |
| Axial load max. | 550 | 900 | 1500 | 2000 |
| Workpiece weight max. kg | 400 | 800 | 1600 | 3200 |
| Concentricity deviation | 0,01 | 0,01 | 0,01 | 0,015 |
| Speed max. min ⁻¹ | 4000 | 3500 | 2500 | 1800 |
| Spare live centres | 009192 | 009205 | 009325 | 009413 |

¹⁾ at max. axial load

MKS - Tip angle 60°

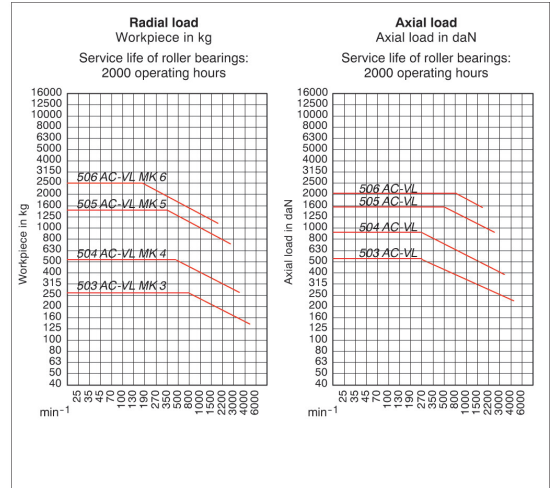
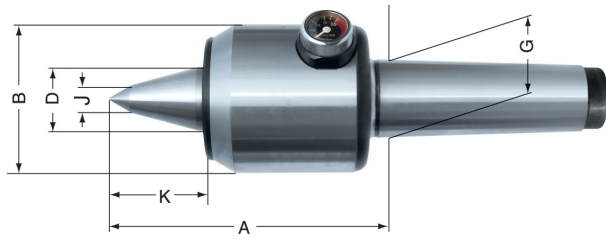

Tool group A06
Type 652-AC-VL
with extended live centre

| Item no. | 079920 ● | 079921 ● | 079922 ● | 079923 ■ |
|------------------------------|----------|----------|----------|----------|
| Mount MT | 3 | 4 | 5 | 6 |
| Size | 503 | 504 | 505 | 506 |
| A | 120 | 137,5 | 177,5 | 223 |
| B | 64 | 72 | 95 | 120 |
| D | 25 | 32 | 40 | 52 |
| G | 23,825 | 31,267 | 44,399 | 63,348 |
| K | 46,5 | 53 | 66 | 80 |
| J | 11 | 14 | 15 | 24 |
| Weight approx. g | 2200 | 3600 | 8400 | 17500 |
| Spring way ¹⁾ | 1,6 | 2 | 1,8 | 2,7 |
| Axial load max. | 550 | 900 | 1500 | 2000 |
| Workpiece weight max. kg | 260 | 550 | 1100 | 2500 |
| Concentricity deviation | 0,01 | 0,01 | 0,01 | 0,015 |
| Speed max. min ⁻¹ | 4000 | 3500 | 2500 | 1800 |
| Spare live centres | 079924 | 079925 | 079926 | 079927 |

¹⁾ at max. axial load

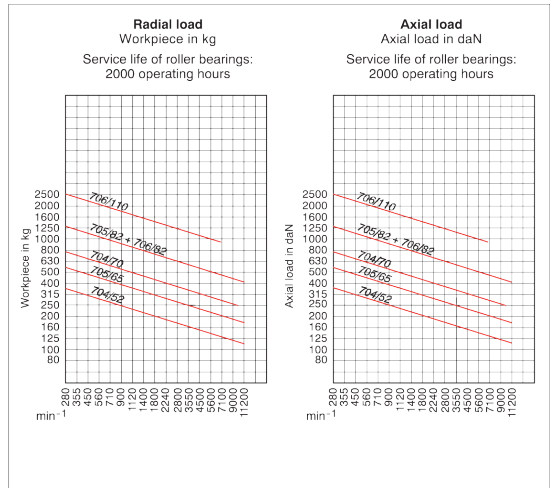
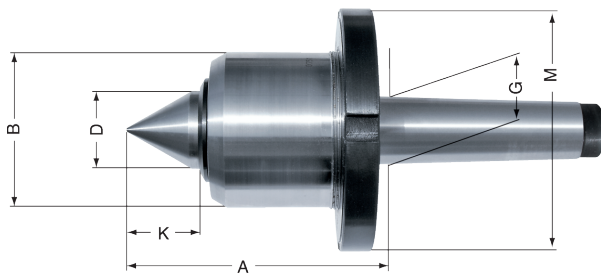

Tool group A06
Type 663
for especially high speeds,
different head diameters at same
size of shank

| Item no. | 340911 ■ | 340910 ■ | 338595 ■ | 338594 ■ | 344808 ▲ | 344809 ▲ |
|------------------------------|----------|----------|----------|----------|----------|----------|
| Mount MT | 4 | 4 | 5 | 5 | 6 | 6 |
| Size | 704/52 | 704/70 | 705/65 | 705/82 | 706/110 | 706/82 |
| A | 90 | 110 | 100 | 130 | 168 | 133 |
| B | 52 | 70 | 65 | 82 | 110 | 82 |
| D | 25 | 35 | 32 | 40 | 55 | 40 |
| G | 31,267 | 31,267 | 44,399 | 44,399 | 63,348 | 63,348 |
| K | 28 | 38 | 34 | 41 | 58 | 41 |
| M | 80 | 110 | 100 | 115 | 150 | 115 |
| Weight approx. g | 1900 | 2300 | 4000 | 5200 | 12000 | 8400 |
| Workpiece weight max. kg | 360 | 800 | 560 | 1250 | 2500 | 1250 |
| Concentricity deviation | 0,005 | 0,005 | 0,005 | 0,005 | 0,005 | 0,005 |
| Speed max. min ⁻¹ | 15000 | 10000 | 12000 | 10000 | 7000 | 10000 |
| Spare live centres | 344924 | 344923 | 338895 | 338901 | 344925 | 338901 |

MKS - Tip angle 60°

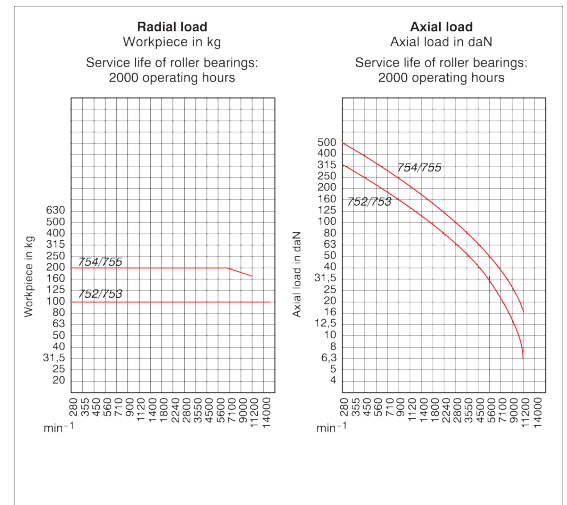
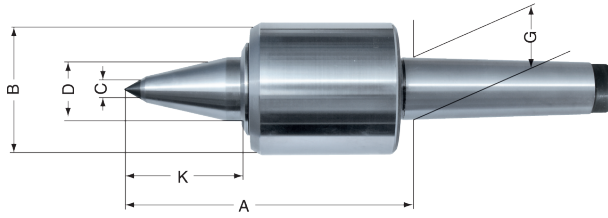

Tool group A06
Type 664
extended NC-centre
with **carbide insert**,
for high speed, powerful, for small
and medium components

| Item no. | 772389 ■ | 772390 ● | 772391 ● | 772392 ● |
|------------------------------|--|---|---|---|
| Mount MT | 2 | 3 | 4 | 5 |
| Size | 752 | 753 | 754 | 755 |
| A | 99 | 99 | 141 | 141 |
| B | 45 | 45 | 66 | 66 |
| C | 7 | 7 | 11 | 11 |
| D | 20 | 20 | 32 | 32 |
| G | 17,78 | 23,825 | 31,267 | 44,399 |
| K | 40 | 40 | 63 | 63 |
| Weight approx. g | 1200 | 1600 | 2600 | 5000 |
| Workpiece weight max. kg | 100 | 100 | 250 | 250 |
| Concentricity deviation | 0,01 | 0,01 | 0,01 | 0,01 |
| Speed max. min ⁻¹ | 12000 | 12000 | 9000 | 9000 |
| Spare live centres | 790267 | 790267 | 790291 | 790291 |

MKS - interchangeable inserts

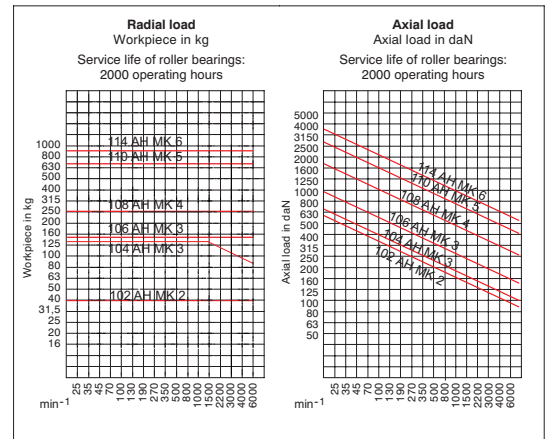
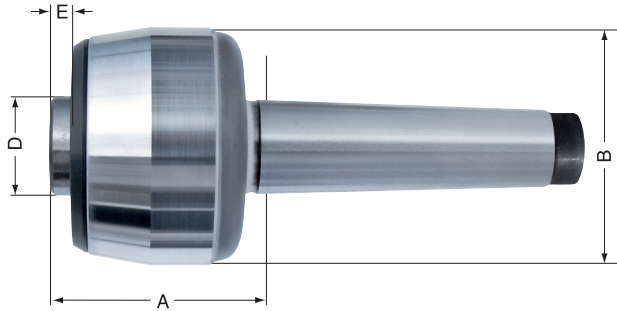

Tool group A06
Type 614
Revolving tailstock centers 100 A
for interchangeable inserts

| Item no. | 061030 ● | 061031 ● | 061032 ● | 061038 ● | 061039 ● | 061040 ● |
|----------------------------------|----------|----------|----------|----------|----------|----------|
| Mount MT | 2 | 3 | 3 | 4 | 5 | 6 |
| Size | 102 | 104 | 106 | 108 | 110 | 114 |
| A | 45 | 48 | 55 | 67 | 85 | 101 |
| B | 45 | 50 | 60 | 70 | 90 | 105 |
| D | 20 | 22 | 25 | 32 | 40 | 50 |
| E | 4 | 4,5 | 5 | 5 | 6 | 6 |
| Concentricity deviation | 0,01 | 0,01 | 0,01 | 0,01 | 0,01 | 0,015 |
| Workpiece weight max. kg | 40 | 130 | 150 | 250 | 650 | 900 |
| Weight without inserts approx. g | 440 | 750 | 1100 | 1900 | 4400 | 8600 |
| Weight | 900 | 1700 | 2200 | 3700 | 8000 | - |
| Speed max. min ⁻¹ | 7000 | 6300 | 5000 | 3800 | 3000 | 2600 |
| Spare live spindle | 009836 | 009838 | 009843 | 009870 | 009872 | 009874 |



Tool group A06
Type 614-00
complete with all inserts in
a sturdy wooden case

| Item no. | 061702 ● | 061703 ● | 061704 ● | 061705 ● | 061706 ● |
|--------------------------|----------|----------|----------|----------|----------|
| Mount MT | 2 | 3 | 3 | 4 | 5 |
| Size | 102 | 104 | 106 | 108 | 110 |
| Workpiece weight max. kg | 40 | 130 | 150 | 250 | 650 |
| Weight | 900 | 1700 | 2200 | 3700 | 8000 |

Interchangeable inserts

Tool group A06
Type 616 Interchangeable inserts **60°**

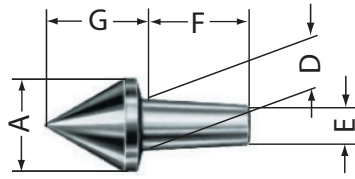

| Item no. | Size | A | D | E | F | G |
|----------|------|----|----|------|----|------|
| 070725 ● | 102 | 16 | 7 | 5,2 | 18 | 20 |
| 070728 ● | 104 | 20 | 12 | 9,6 | 24 | 24 |
| 070731 ● | 106 | 24 | 12 | 9,6 | 24 | 27,5 |
| 070734 ● | 108 | 28 | 15 | 12 | 30 | 31,5 |
| 070737 ● | 110 | 38 | 22 | 18,5 | 35 | 43 |
| 070740 ● | 114 | 50 | 28 | 24 | 40 | 54 |

Tool group A06
Type 616 Interchangeable inserts **75°**

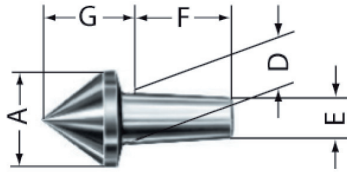

| Item no. | Size | A | D | E | F | G |
|----------|------|----|----|------|----|------|
| 070726 ■ | 102 | 16 | 7 | 5,2 | 18 | 17 |
| 070729 ■ | 104 | 20 | 12 | 9,6 | 24 | 19,5 |
| 070732 ■ | 106 | 24 | 12 | 9,6 | 24 | 22,5 |
| 070735 ■ | 108 | 28 | 15 | 12 | 30 | 25,5 |
| 070738 ■ | 110 | 38 | 22 | 18,5 | 35 | 35 |
| 070741 ■ | 114 | 50 | 28 | 24 | 40 | 44 |

Tool group A06
Type 616 Interchangeable inserts **90°**

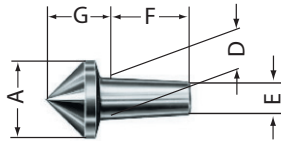

| Item no. | Size | A | D | E | F | G |
|----------|------|----|----|------|----|------|
| 070727 ● | 102 | 16 | 7 | 5,2 | 18 | 14,5 |
| 070730 ● | 104 | 20 | 12 | 9,6 | 24 | 16,5 |
| 070733 ● | 106 | 24 | 12 | 9,6 | 24 | 19 |
| 070736 ● | 108 | 28 | 15 | 12 | 30 | 21,5 |
| 070739 ● | 110 | 38 | 22 | 18,5 | 35 | 29 |
| 070742 ■ | 114 | 50 | 28 | 24 | 40 | 36 |

Tool group A06
Type 616 Interchangeable inserts **60°VL**

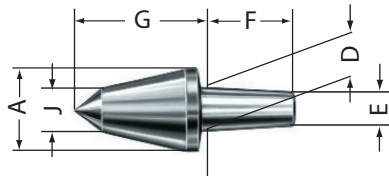

| Item no. | Size | A | D | E | F | G | J |
|----------|----------|----|----|------|----|----|------|
| 070719 ● | 102 | 14 | 7 | 5,2 | 18 | 25 | 6 |
| 070720 ● | 104; 106 | 18 | 12 | 9,6 | 24 | 30 | 8 |
| 070721 ● | 108 | 26 | 15 | 12 | 30 | 43 | 12 |
| 070722 ● | 110 | 32 | 22 | 18,5 | 35 | 55 | 13 |
| 070723 ● | 114 | 42 | 28 | 24 | 40 | 70 | 18,5 |

Tool group A06
Type 616 Interchangeable inserts for tubular workpieces **60°**

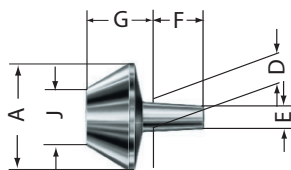

| Item no. | Size | A | D | E | F | G | J |
|----------|------|-----|----|------|----|------|----|
| 070700 ● | 102 | 25 | 7 | 5,2 | 18 | 21 | 10 |
| 070701 ● | 104 | 35 | 12 | 9,6 | 24 | 26 | 15 |
| 070702 ● | 106 | 45 | 12 | 9,6 | 24 | 27 | 25 |
| 070703 ● | 108 | 55 | 15 | 12 | 30 | 31,5 | 30 |
| 070704 ● | 110 | 70 | 22 | 18,5 | 35 | 39 | 40 |
| 070705 ● | 114 | 100 | 28 | 24 | 40 | 52 | 55 |

Tool group A06
Type 616 Interchangeable inserts **A** for centerless workpieces **60°**

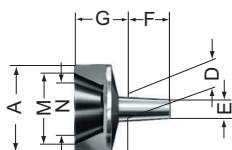

| Item no. | Size | A | D | E | F | G | M | N |
|----------|------|-----|----|------|----|----|----|----|
| 070707 ● | 102 | 25 | 7 | 5,2 | 18 | 18 | 20 | 10 |
| 070708 ● | 104 | 35 | 12 | 9,6 | 24 | 24 | 30 | 15 |
| 070709 ● | 106 | 45 | 12 | 9,6 | 24 | 25 | 40 | 25 |
| 070710 ● | 108 | 55 | 15 | 12 | 30 | 30 | 48 | 30 |
| 070711 ■ | 110 | 70 | 22 | 18,5 | 35 | 39 | 63 | 40 |
| 070712 ■ | 114 | 100 | 28 | 24 | 40 | 52 | 90 | 55 |

Interchangeable inserts

Tool group A06
Type 616 Interchangeable inserts **B** for centerless workpieces 60°

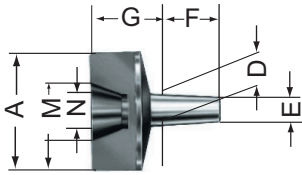

| Item no. | Size | A | D | E | F | G | M | N |
|----------|------|----|----|------|----|----|----|----|
| 228620 ● | 102 | 16 | 7 | 5,2 | 18 | 12 | 12 | 6 |
| 228621 ● | 106 | 22 | 12 | 9,6 | 24 | 16 | 18 | 10 |
| 228622 ● | 108 | 40 | 15 | 12 | 30 | 25 | 35 | 20 |
| 308632 ■ | 110 | 52 | 22 | 18,5 | 35 | 30 | 45 | 30 |

Tool group A06
Type 616 **Extractor**



| Item no. | For size |
|----------|-------------|
| 061707 ● | 102 |
| 061708 ● | 104/106/108 |
| 061709 ● | 110/114 |

MKS heavy

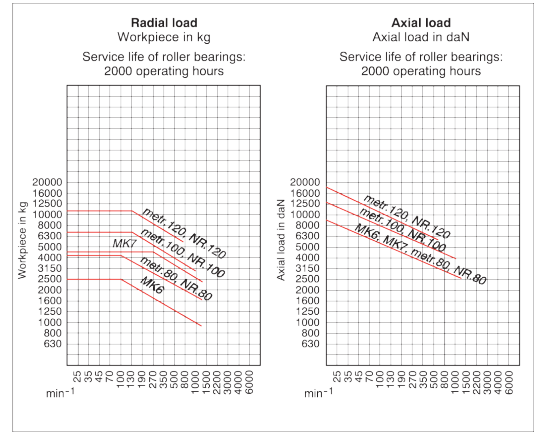
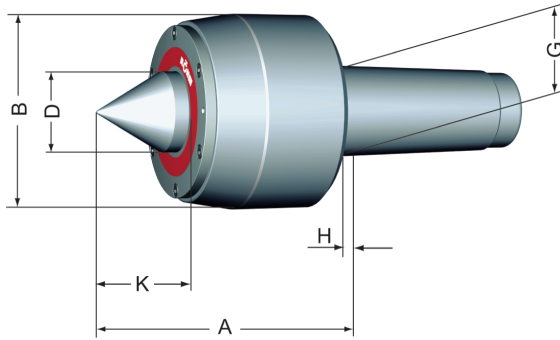

Tool group A06
Type 604
without draw-off nut

| Item no. | 093439 ● | 466229 ■ | 093440 ● | 058674 ■ | 018801 ■ | 093446 ■ | 058675 ▲ | 466230 ▲ |
|--------------------------|----------|----------|----------|------------------|------------------|---------------|----------------|----------------|
| Mount | MK 6 | MK 7 | Metr. 80 | Metr. 100 (1:20) | Metr. 120 (1:20) | Nr. 80 (1:10) | Nr. 100 (1:10) | Nr. 120 (1:10) |
| A | 196 | 215 | 196 | 257 | 274 | 196 | 257 | 274 |
| B | 140 | 150 | 140 | 200 | 245 | 140 | 200 | 245 |
| D | 60 | 70 | 60 | 85 | 110 | 60 | 85 | 110 |
| G | 63,348 | 83,061 | 80 | 100 | 120 | 80 | 100 | 120 |
| H | 13 | 15 | 13 | 14 | 15 | 13 | 14 | 15 |
| K | 67 | 77 | 68 | 86 | 102 | 66 | 86 | 102 |
| Workpiece weight max. kg | 5000 | 9000 | 8500 | 13000 | 22000 | 8500 | 13000 | 22000 |
| Concentricity deviation | 0,01 | 0,01 | 0,015 | 0,01 | 0,01 | 0,01 | 0,01 | 0,01 |

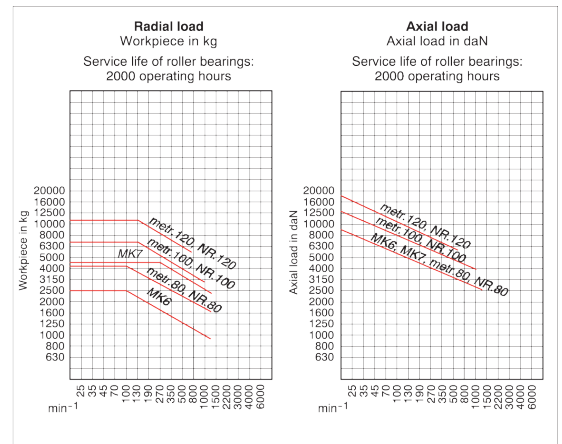
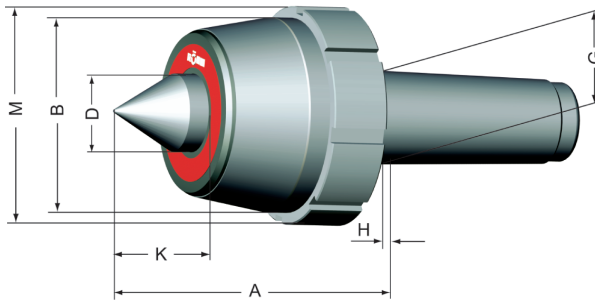

Tool group A06
Type 604 MA
with draw-off nut

| Item no. | 466231 ■ | 466232 ■ | 466233 ■ | 466234 ■ | 466235 ▲ | 466236 ▲ | 466237 ▲ | 466238 ▲ |
|--------------------------|----------|----------|-----------------|------------------|------------------|---------------|----------------|----------------|
| Mount | MK 6 | MK 7 | Metr. 80 (1:20) | Metr. 100 (1:20) | Metr. 120 (1:20) | Nr. 80 (1:10) | Nr. 100 (1:10) | Nr. 120 (1:10) |
| A | 196 | 215 | 196 | 257 | 274 | 196 | 257 | 274 |
| B | 140 | 150 | 140 | 200 | 245 | 140 | 200 | 245 |
| D | 60 | 70 | 60 | 85 | 110 | 60 | 85 | 110 |
| G | 63,348 | 83,061 | 80 | 100 | 120 | 80 | 100 | 120 |
| H | 13 | 15 | 13 | 14 | 15 | 13 | 14 | 15 |
| K | 66 | 77 | 66 | 86 | 102 | 66 | 86 | 102 |
| M | 158 | 168 | 158 | 224 | 270 | 158 | 224 | 270 |
| Workpiece weight max. kg | 5000 | 9000 | 8500 | 13000 | 22000 | 8500 | 13000 | 22000 |
| Concentricity deviation | 0,01 | 0,01 | 0,01 | 0,01 | 0,01 | 0,01 | 0,01 | 0,01 |

MKS heavy

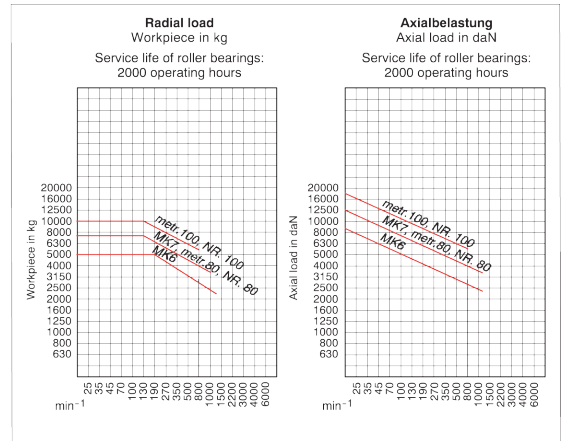
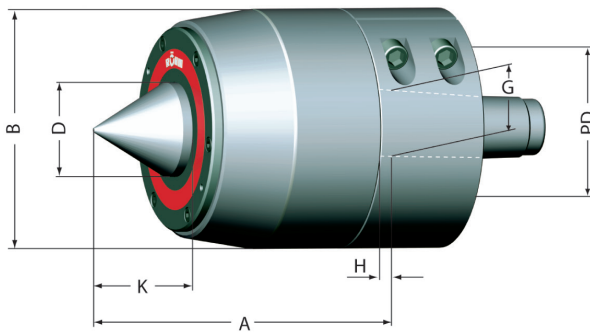

Tool group A06
Type 604
with tailstock support

| Item no. | 466239 ▲ | 466240 ▲ | 466241 ▲ | 466242 ▲ | 466243 ▲ | 466244 ▲ |
|--------------------------|----------|----------|-----------------|------------------|---------------|----------------|
| Mount | MK 6 | MK 7 | Metr. 80 (1:20) | Metr. 100 (1:20) | Nr. 80 (1:10) | Nr. 100 (1:10) |
| A | 254 | 270 | 269 | 298 | 269 | 298 |
| B | 230 | 240 | 240 | 260 | 240 | 260 |
| D | 85 | 95 | 95 | 108 | 95 | 108 |
| G | 63,348 | 83,061 | 80 | 100 | 80 | 100 |
| H | 13 | 15 | 13 | 14 | 13 | 14 |
| K | 86 | 92 | 92 | 102 | 92 | 102 |
| max. PD 1) | 170 | 180 | 180 | 200 | 180 | 200 |
| Workpiece weight max. kg | 10000 | 15000 | 15000 | 20000 | 15000 | 20000 |
| Concentricity deviation | 0,01 | 0,01 | 0,01 | 0,01 | 0,01 | 0,01 |

1) Tailstock dia. according to customers details

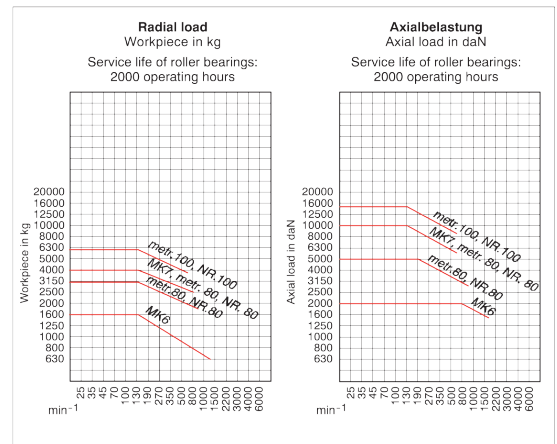
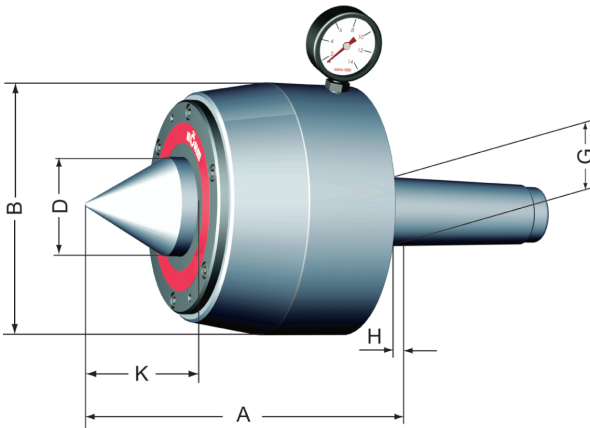

Tool group A06
Type 652
with length compensation
and pressure indicator

| Item no. | 466245 ▲ | 466246 ▲ | 466247 ▲ | 466248 ▲ | 466249 ▲ | 466250 ▲ | 466251 ▲ |
|--------------------------|----------|-----------------|-----------------|------------------|---------------|---------------|----------------|
| Mount | MK 7 | Metr. 80 (1:20) | Metr. 80 (1:20) | Metr. 100 (1:20) | Nr. 80 (1:10) | Nr. 80 (1:10) | Nr. 100 (1:10) |
| A | 278 | 209 | 276 | 310 | 209 | 276 | 310 |
| B | 195 | 145 | 195 | 230 | 145 | 195 | 230 |
| D | 85 | 60 | 85 | 100 | 60 | 85 | 100 |
| G | 83,061 | 80 | 80 | 100 | 80 | 80 | 100 |
| H | 15 | 13 | 13 | 14 | 13 | 13 | 14 |
| K | 88 | 62 | 88 | 96 | 62 | 88 | 96 |
| Workpiece weight max. kg | 8000 | 6000 | 8000 | 12000 | 6000 | 8000 | 12000 |
| Concentricity deviation | 0,015 | 0,015 | 0,015 | 0,015 | 0,015 | 0,015 | 0,015 |
| Spring way max. | 4,5 | 3,4 | 4,5 | 4,5 | 3,4 | 4,5 | 4,5 |
| Axial pressure max. | 10000 | 5000 | 10000 | 14000 | 5000 | 10000 | 14000 |

MKS heavy

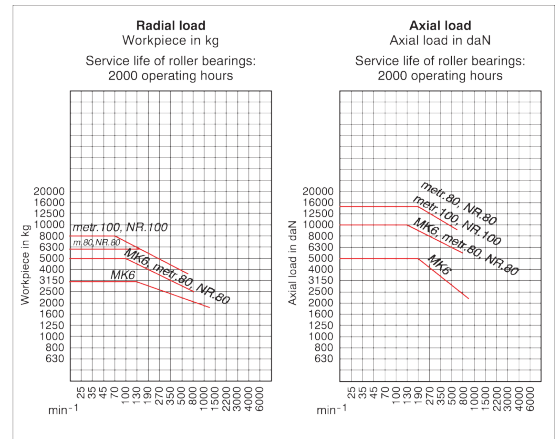
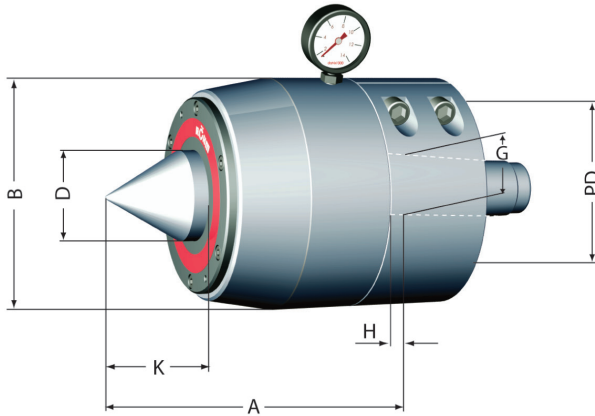

Tool group A06
Type 652
with **length compensation,**
pressure indicator
and **tailstock support**

| Item no. | 466252 ▲ | 466253 ▲ | 466254 ▲ | 466255 ▲ | 466256 ▲ | 466257 ▲ | 466258 ▲ | 466259 ▲ |
|--------------------------|----------|----------|-----------------|-----------------|------------------|---------------|---------------|----------------|
| Mount | MK 6 | MK 6 | Metr. 80 (1:20) | Metr. 80 (1:20) | Metr. 100 (1:20) | Nr. 80 (1:10) | Nr. 80 (1:10) | Nr. 100 (1:10) |
| A | 209 | 278 | 278 | 310 | 310 | 278 | 310 | 310 |
| B | 210 | 240 | 240 | 290 | 290 | 240 | 290 | 290 |
| D | 60 | 85 | 85 | 100 | 100 | 85 | 100 | 100 |
| G | 63,348 | 63,348 | 80 | 80 | 100 | 80 | 80 | 100 |
| H | 13 | 13 | 13 | 13 | 14 | 13 | 13 | 14 |
| K | 62 | 88 | 88 | 96 | 96 | 88 | 96 | 96 |
| max. PD 1) | 150 | 180 | 180 | 220 | 220 | 180 | 220 | 220 |
| Workpiece weight max. kg | 6000 | 10000 | 10000 | 12000 | 15000 | 10000 | 12000 | 15000 |
| Concentricity deviation | 0,015 | 0,015 | 0,015 | 0,015 | 0,015 | 0,015 | 0,015 | 0,015 |
| Spring way max. | 3,4 | 4,5 | 4,5 | 4,5 | 4,5 | 4,5 | 4,5 | 4,5 |
| Axial pressure max. | 5000 | 10000 | 10000 | 14000 | 14000 | 10000 | 14000 | 14000 |

1) Tailstock dia. according to customers details

MZK

Tool group A06
Type 608-00 Revolving centering tapers

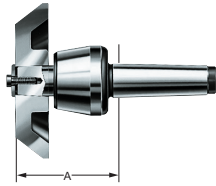

| Item no. | Size | Mount MT | A | Workpiece weight max. kg | Weight |
|----------|------|----------|-----|--------------------------|--------|
| 304562 ● | 108 | 4 | 103 | 800 | 2200 |
| 304563 ● | 110 | 5 | 128 | 1600 | 4800 |
| 304564 ● | 114 | 6 | 159 | 3000 | 12000 |

Including fixing screw and washer, without insert

Tool group A06
Type 640-90 Revolving centering tapers **with draw-off nut**, for high load

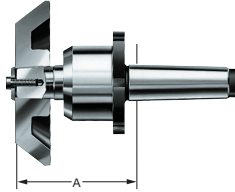

| Item no. | Size | Mount MT | A | Workpiece weight max. kg | Weight |
|----------|------|----------|-----|--------------------------|--------|
| 304583 ● | 494 | 4 | 118 | 1000 | 3200 |
| 304584 ● | 495 | 5 | 140 | 2000 | 6500 |
| 304585 ■ | 496 | 6 | 168 | 3500 | 13500 |

Including fixing screw and washer, without insert

Tool group A07
Type 698-00 **Fixed shafts**

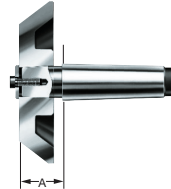

| Item no. | Mount MT | A | Workpiece weight max. kg | Weight |
|----------|----------|----|--------------------------|--------|
| 304580 ● | 4 | 45 | 2000 | 800 |
| 304581 ● | 5 | 60 | 4800 | 2000 |
| 304582 ● | 6 | 70 | 12000 | 5500 |

Including fixing screw and washer, without insert

Accessories MZK

Tool group A06
Type 608-20
Suitable **inserts** for centering tapers **AZ**
Standard version, taper 75°

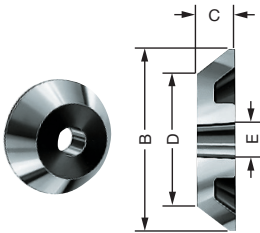

| Item no. | Size | for MT | B | C | D | E | Weight |
|------------------------|------|--------|-----|----|-----|----|--------|
| 304565 ¹⁾ ● | 1 | 4 | 60 | 68 | 5 | 32 | 900 |
| 304566 ● | 2 | 4 | 100 | 45 | 45 | 32 | 1500 |
| 304567 ● | 3 | 4 | 150 | 45 | 95 | 32 | 4100 |
| 304568 ● | 4 | 4 | 200 | 45 | 145 | 32 | 6000 |
| 304569 ● | 5 | 4 | 250 | 45 | 195 | 32 | 8500 |
| 304570 ● | 1 | 5 | 100 | 43 | 45 | 40 | 1500 |
| 304571 ● | 2 | 5 | 150 | 43 | 95 | 40 | 4400 |
| 304572 ● | 3 | 5 | 200 | 43 | 145 | 40 | 6100 |
| 304573 ● | 4 | 5 | 250 | 43 | 195 | 40 | 8100 |
| 304574 ● | 5 | 5 | 300 | 43 | 245 | 40 | 11600 |
| 304575 ● | 1 | 6 | 150 | 54 | 95 | 50 | 3000 |
| 304576 ● | 2 | 6 | 200 | 54 | 145 | 50 | 8100 |
| 304577 ● | 3 | 6 | 250 | 54 | 195 | 50 | 11100 |
| 304578 ● | 4 | 6 | 300 | 54 | 245 | 50 | 14000 |
| 304579 ● | 5 | 6 | 350 | 54 | 295 | 50 | 18800 |

¹⁾ Without fixing by screw and washer

Tool group A06
Type 608-40
Suitable **inserts** for centering tapers **AZR**
with three support surfaces,
for rough pieces 75°

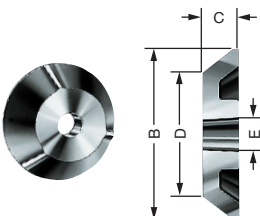

| Item no. | Size | for MT | B | C | D | E | Weight |
|----------|------|--------|-----|----|-----|----|--------|
| 304736 ■ | 2 | 4 | 100 | 45 | 45 | 32 | 1500 |
| 304737 ■ | 3 | 4 | 150 | 45 | 95 | 32 | 4100 |
| 304738 ■ | 4 | 4 | 200 | 45 | 145 | 32 | 6000 |
| 304739 ■ | 5 | 4 | 250 | 45 | 195 | 32 | 8500 |
| 304740 ■ | 1 | 5 | 100 | 43 | 45 | 40 | 1500 |
| 304741 ■ | 2 | 5 | 150 | 43 | 95 | 40 | 4400 |
| 304742 ■ | 3 | 5 | 200 | 43 | 145 | 40 | 6100 |
| 304743 ■ | 4 | 5 | 250 | 43 | 195 | 40 | 8100 |
| 304744 ■ | 5 | 5 | 300 | 43 | 245 | 40 | 11600 |
| 304745 ■ | 1 | 6 | 150 | 54 | 95 | 50 | 3000 |
| 304746 ■ | 2 | 6 | 200 | 54 | 145 | 50 | 8100 |
| 304747 ■ | 3 | 6 | 250 | 54 | 195 | 50 | 11100 |
| 304748 ■ | 4 | 6 | 300 | 54 | 245 | 50 | 14000 |
| 304749 ■ | 5 | 6 | 350 | 54 | 295 | 50 | 18800 |

Tool group A06
 Type 627 Revolving centering taper, **pointed**
 as centering taper for tubular workpieces and as a revolving tailstock centre
 to machine normal workpieces

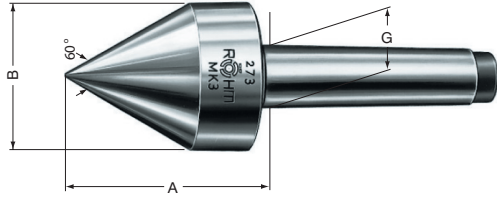

| Item no. | Size | Mount MT | A | B | G | Workpiece weight max. kg | Concentricity deviation | Weight |
|----------|------|----------|-------|-----|--------|--------------------------|-------------------------|--------|
| 010613 | 272 | 2 | 61 | 42 | 17,78 | 200 | 0,01 | 400 |
| 010635 | 273 | 3 | 79 | 56 | 23,825 | 400 | 0,008 | 1100 |
| 010638 | 274 | 4 | 100 | 64 | 31,267 | 800 | 0,008 | 1600 |
| 010642 | 275 | 5 | 115,5 | 78 | 44,399 | 1600 | 0,008 | 3600 |
| 306396 | 276 | 6 | 153 | 105 | 63,348 | 2500 | 0,008 | 10000 |

Tool group A06
 Type 617 Revolving tailstock center, **cone truncated, 60°**

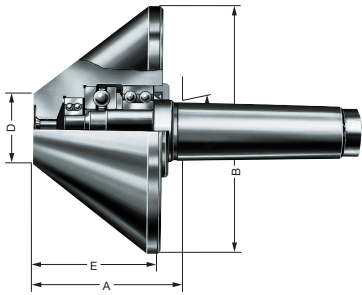

| Item no. | Size | Mount MT | A | B | D | E | Workpiece weight max. kg | Concentricity deviation | Weight |
|----------|------|----------|------|-----|----|----|--------------------------|-------------------------|--------|
| 301615 | 171 | 1 | 64 | 50 | 20 | 52 | 100 | 0,008 | 900 |
| 301616 | 171a | 2 | 65 | 50 | 20 | 52 | 200 | 0,008 | 1200 |
| 301556 | 172 | 2 | 77 | 80 | 30 | 64 | 300 | 0,008 | 2000 |
| 301557 | 172a | 3 | 77 | 80 | 30 | 64 | 400 | 0,008 | 2200 |
| 221605 | 173 | 3 | 96,5 | 120 | 30 | 83 | 600 | 0,008 | 4200 |
| 301558 | 172b | 4 | 78,5 | 80 | 30 | 64 | 400 | 0,008 | 2300 |
| 044023 | 173a | 4 | 98 | 120 | 30 | 83 | 800 | 0,008 | 4500 |
| 090483 | 173b | 5 | 99 | 120 | 30 | 83 | 800 | 0,008 | 5300 |

Tool group A06
 Type 618 Revolving tailstock center, **cone truncated, 75°**

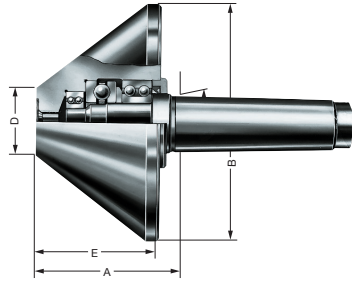

| Item no. | Size | Mount MT | A | B | D | E | Workpiece weight max. kg | Concentricity deviation | Weight |
|----------|------|----------|-------|-----|-----|-----|--------------------------|-------------------------|--------|
| 301559 | 172 | 2 | 80 | 80 | 20 | 67 | 300 | 0,008 | 2000 |
| 301560 | 172a | 3 | 80 | 80 | 20 | 67 | 400 | 0,008 | 2000 |
| 062211 | 173 | 3 | 85,5 | 120 | 30 | 72 | 600 | 0,008 | 4200 |
| 301561 | 172b | 4 | 81,5 | 80 | 20 | 67 | 400 | 0,008 | 2400 |
| 062224 | 173a | 4 | 87 | 120 | 30 | 72 | 800 | 0,008 | 4300 |
| 062299 | 174 | 4 | 107 | 170 | 50 | 90 | 1200 | 0,01 | 9700 |
| 062232 | 173b | 5 | 88 | 120 | 30 | 72 | 800 | 0,008 | 5100 |
| 063614 | 174a | 5 | 106 | 170 | 50 | 90 | 1600 | 0,01 | 10600 |
| 063662 | 175 | 5 | 146,5 | 250 | 75 | 130 | 2000 | 0,01 | 34000 |
| 063633 | 174b | 6 | 107,5 | 170 | 50 | 90 | 1600 | 0,01 | 13300 |
| 063656 | 175a | 6 | 148 | 250 | 75 | 130 | 2000 | 0,01 | 37000 |
| 063680 | 176 | 6 | 184 | 350 | 120 | 168 | 4000 | 0,015 | 82000 |



Dead centres DIN 806 and DIN 807 completely hardened and ground (with carbide-tipped ground only). Different types available.

Dead centres are manufactured with a concentricity of 5 micrometers. Versions with a concentricity of 3 micrometers or better are available for an extra charge.

Technical features:

- completely hardened and ground
- high concentricity
- heavy duty

Tool group A07
Type 665 **DIN 806, full point**
material: tool steel

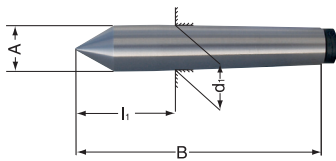

| Item no. | Mount MT | A | B | d1 | l1 | Weight |
|----------|----------|------|-----|--------|------|--------|
| 013706 ● | 0 | 9,2 | 70 | 9,045 | 20 | 30 |
| 013707 ● | 1 | 12,2 | 80 | 12,065 | 26,5 | 60 |
| 013709 ● | 2 | 18 | 100 | 17,78 | 36 | 150 |
| 013711 ● | 3 | 24,1 | 125 | 23,825 | 44 | 340 |
| 013712 ● | 4 | 31,6 | 160 | 31,267 | 57,5 | 760 |
| 013715 ● | 5 | 44,7 | 200 | 44,399 | 70,5 | 1920 |
| 013718 ● | 6 | 63,8 | 270 | 63,348 | 88 | 5200 |

Tool group A07
Type 666 **DIN 806, full point**
material: SS-high speed steel, from MT 4 only point in SS

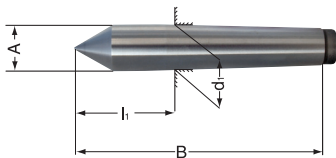

| Item no. | Mount MT | A | B | d1 | l1 | Weight |
|----------|----------|------|-----|--------|------|--------|
| 013790 ● | 0 | 9,2 | 70 | 9,045 | 20 | 30 |
| 013791 ● | 1 | 12,2 | 80 | 12,065 | 26,5 | 60 |
| 013792 ● | 2 | 18 | 100 | 17,78 | 36 | 150 |
| 013793 ● | 3 | 24,1 | 125 | 23,825 | 44 | 340 |
| 013794 ● | 4 | 31,6 | 160 | 31,267 | 57,5 | 760 |
| 013797 ● | 5 | 44,7 | 200 | 44,399 | 70,5 | 1920 |
| 013799 ● | 6 | 63,8 | 270 | 63,348 | 88 | 5200 |

Tool group A07
Type 667 **DIN 806, full point, ground only carbide-tipped**

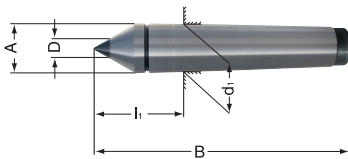

| Item no. | Mount MT | A | B | D | d1 | l1 | Weight |
|----------|----------|------|-----|----|--------|------|--------|
| 017169 ● | 0 | 9,2 | 70 | 5 | 9,045 | 20 | 30 |
| 017170 ● | 1 | 12,2 | 80 | 7 | 12,065 | 26,5 | 55 |
| 017171 ● | 2 | 18 | 100 | 7 | 17,78 | 36 | 155 |
| 017172 ● | 3 | 24,1 | 125 | 11 | 23,825 | 44 | 360 |
| 017173 ● | 4 | 31,6 | 160 | 14 | 31,267 | 57,5 | 770 |
| 017174 ● | 5 | 44,7 | 200 | 18 | 44,399 | 70,5 | 1950 |
| 017175 ● | 6 | 63,8 | 270 | 18 | 63,348 | 88 | 5200 |

Tool group A07
Type 677 **DIN 806, full point, ground only carbide-tipped full point**

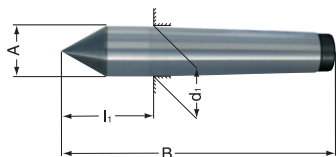

| Item no. | Mount MT | A | B | d1 | l1 | Weight |
|----------|----------|------|-----|--------|------|--------|
| 326786 ● | 2 | 18 | 100 | 17,78 | 36 | 175 |
| 306402 ● | 3 | 24,1 | 125 | 23,825 | 44 | 400 |
| 221398 ● | 4 | 31,6 | 160 | 31,267 | 57,5 | 855 |
| 326816 ● | 5 | 44,7 | 200 | 44,399 | 70,5 | 2160 |

Tool group A07
Type 668 **DIN 806, half point**
material: tool steel

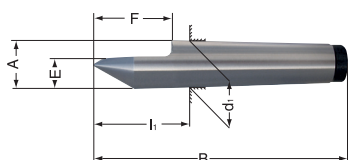

| Item no. | Mount MT | A | B | E | F | d1 | l1 | Weight |
|----------|----------|------|-----|------|----|--------|------|--------|
| 013867 ● | 1 | 12,2 | 80 | 7,6 | 22 | 12,065 | 26,5 | 55 |
| 013868 ● | 2 | 18 | 100 | 11 | 30 | 17,78 | 36 | 145 |
| 013870 ● | 3 | 24,1 | 125 | 15 | 38 | 23,825 | 44 | 310 |
| 013871 ● | 4 | 31,6 | 160 | 21 | 50 | 31,267 | 57,5 | 710 |
| 013997 ● | 5 | 44,7 | 200 | 29,4 | 63 | 44,399 | 70,5 | 1925 |
| 013999 ● | 6 | 63,8 | 270 | 42 | 79 | 63,348 | 88 | 4800 |

Tool group A07
Type 670 **DIN 806, half point**, ground only
carbide-tipped

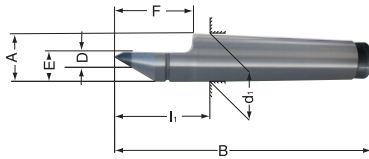

| Item no. | Mount MT | A | B | D | E | F | d1 | I1 | Weight |
|----------|----------|------|-----|----|------|----|--------|------|--------|
| 027438 ● | 1 | 12,2 | 80 | 7 | 7,6 | 22 | 12,065 | 26,5 | 55 |
| 027439 ● | 2 | 18 | 100 | 7 | 11 | 30 | 17,78 | 36 | 150 |
| 027440 ● | 3 | 24,1 | 125 | 11 | 15 | 38 | 23,825 | 44 | 335 |
| 026571 ● | 4 | 31,6 | 160 | 14 | 21 | 50 | 31,267 | 57,5 | 750 |
| 027441 ▲ | 5 | 44,7 | 200 | 18 | 29,4 | 63 | 44,399 | 70,5 | 1830 |

Tool group A07
Type 671 similar **DIN 807, full point** with draw-off nut
material: tool steel

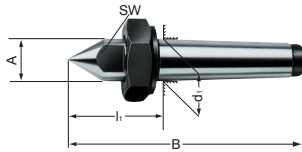

| Item no. | Mount MT | A | B | C | d1 | I1 | Key-width SW | Weight |
|----------|----------|------|-----|---------|--------|------|--------------|--------|
| 005361 ● | 1 | 12,2 | 90 | M16x1,5 | 12,065 | 36,5 | 10 | 140 |
| 005553 ● | 2 | 18 | 112 | M22x1,5 | 17,78 | 48 | 14 | 300 |
| 005654 ● | 3 | 24,1 | 138 | M27x1,5 | 23,825 | 57 | 19 | 580 |
| 005357 ● | 4 | 31,6 | 175 | M36x1,5 | 31,267 | 72,5 | 27 | 800 |
| 005381 ● | 5 | 44,7 | 217 | M48x1,5 | 44,399 | 87,5 | 36 | 2900 |
| 005426 ● | 6 | 63,8 | 290 | M68x1,5 | 63,348 | 108 | 55 | 7200 |

Tool group A07
Type 671 **Draw-off nut**

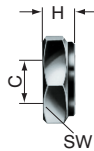

| Item no. | C | H | Key-width SW | Weight |
|----------|---------|------|--------------|--------|
| 005363 ● | M16x1,5 | 12 | 24 | 26 |
| 005555 ● | M22x1,5 | 15,5 | 32 | 55 |
| 005656 ● | M27x1,5 | 17,5 | 41 | 110 |
| 005359 ● | M36x1,5 | 21 | 55 | 240 |
| 005383 ● | M48x1,5 | 23 | 75 | 480 |
| 005428 ● | M68x1,5 | 25,5 | 100 | 900 |

Tool group A07
Type 672 similar **DIN 807, full point** with draw-off nut, with extended point
material: tool steel

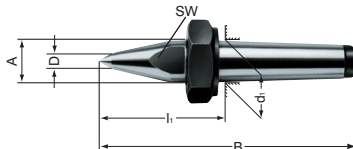

| Item no. | Mount MT | A | B | C | D | d1 | I1 | Key-width SW | Weight |
|----------|----------|------|-------|---------|----|--------|-----|--------------|--------|
| 249575 ● | 2 | 18 | 118 | M22x1,5 | 10 | 17,78 | 54 | 14 | 300 |
| 249576 ● | 3 | 24,1 | 148 | M27x1,5 | 10 | 23,825 | 67 | 19 | 600 |
| 249577 ● | 4 | 31,6 | 186,5 | M36x1,5 | 14 | 31,267 | 84 | 27 | 1285 |
| 249578 ● | 5 | 44,7 | 242 | M48x1,5 | 16 | 44,399 | 112 | 36 | 3000 |
| 249579 ● | 6 | 63,8 | 330 | M68x1,5 | 20 | 63,348 | 148 | 55 | 7900 |

Tool group A07
Type 671 **Draw-off nut**

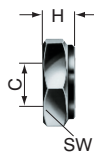

| Item no. | C | H | Key-width SW | Weight |
|----------|---------|------|--------------|--------|
| 005555 ● | M22x1,5 | 15,5 | 32 | 55 |
| 005656 ● | M27x1,5 | 17,5 | 41 | 110 |
| 005359 ● | M36x1,5 | 21 | 55 | 240 |
| 005383 ● | M48x1,5 | 23 | 75 | 480 |
| 005428 ● | M68x1,5 | 25,5 | 100 | 900 |

Tool group A07
Type 673 **full point** with centre bore
material: tool steel

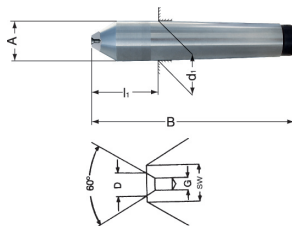

| Item no. | Mount MT | A | B | D | G | d1 | I1 | Weight |
|----------|----------|------|------|-----|------|--------|------|--------|
| 015001 ▲ | 1 | 12,2 | 77 | 2,5 | 1 | 12,065 | 23,5 | 60 |
| 015003 ▲ | 2 | 18 | 95,5 | 4 | 1,6 | 17,78 | 31,5 | 170 |
| 015004 ● | 3 | 24,1 | 120 | 5 | 2 | 23,825 | 39 | 350 |
| 015005 ▲ | 4 | 31,6 | 153 | 6,5 | 2,5 | 31,267 | 50,5 | 800 |
| 015006 ▲ | 5 | 44,7 | 191 | 8 | 3,19 | 44,399 | 61,5 | 1900 |

Tool group A07
 Typ 674 **half point** with centre bore
 material: tool steel

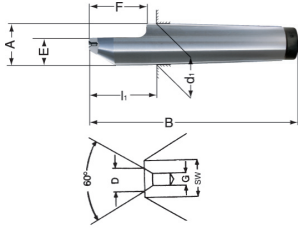

| Item no. | Mount MT | A | B | D | E | F | G | d1 | l1 | Weight |
|----------|----------|------|------|-----|------|----|------|--------|------|--------|
| 015009 ● | 1 | 12,2 | 77 | 2,5 | 8,6 | 19 | 1 | 12,065 | 23,5 | 55 |
| 015010 ● | 2 | 18 | 95,5 | 4 | 12 | 26 | 1,6 | 17,78 | 31,5 | 150 |
| 015011 ● | 3 | 24,1 | 120 | 5 | 15,7 | 32 | 2 | 23,825 | 39 | 310 |
| 015022 ■ | 4 | 31,6 | 153 | 6,5 | 20,8 | 42 | 2,5 | 31,267 | 50,5 | 705 |
| 015023 ■ | 5 | 44,7 | 191 | 8 | 29,4 | 53 | 3,15 | 44,399 | 61,5 | 1800 |

Tool group A07
 Type 695 **DIN 806, full point** with spanner flat
 material: tool steel

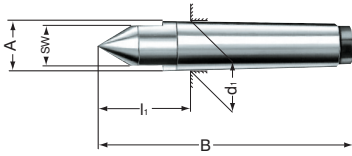

| Item no. | Mount MT | A | B | d1 | l1 | Key-width SW | Weight |
|----------|----------|------|-----|--------|------|--------------|--------|
| 015028 ■ | 1 | 12,2 | 80 | 12,065 | 26,5 | 10 | 55 |
| 015032 ● | 2 | 18 | 100 | 17,78 | 36 | 14 | 145 |
| 015039 ● | 3 | 24,1 | 125 | 23,825 | 44 | 19 | 340 |
| 015042 ● | 4 | 31,6 | 160 | 31,267 | 57,5 | 27 | 740 |
| 015040 ● | 5 | 44,7 | 200 | 44,399 | 70,5 | 36 | 1860 |

Overview

CoA

For efficient high-precision turning of workpieces along their whole length without rechucking. The modular principle design allows the unlimited exchange of driver disks and centres. The hydraulic or mechanical compensation system guarantees equal clamping forces even on uneven workpiece faces. The spring cushioned centre allows the axial stop at the face of the workpiece.
Clamping diameter 8-80 mm
Max. workpiece weight 100 kg

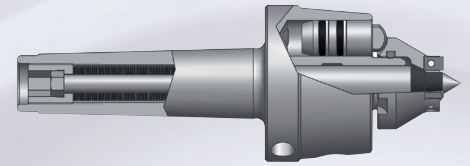

CoE

New Product!

For efficient high-precision turning of workpieces along their whole length without rechucking. In the same operation there may be also milled a groove or toothing. This could save a retooling, i. e. to a vice, which may turn out to be both time and money saving. The modular principle design allows the unlimited exchange of driver disks and centres. The mechanical compensation system guarantees equal clamping forces even on uneven workpiece faces. The spring cushioned centre allows the axial stop at the face of the workpiece.
Clamping diameter 8-80 mm
Max. workpiece weight 100 kg

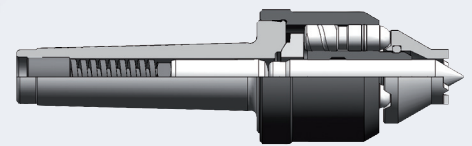

CoM

With spring loaded centre, attachable driver disk and mechanical compensation system. Adaptor flange with disk spring package or basic body with morse taper. For the clamping of big and heavy workpieces.
Clamping diameter 50-250 mm
Max. workpiece weight 500 kg

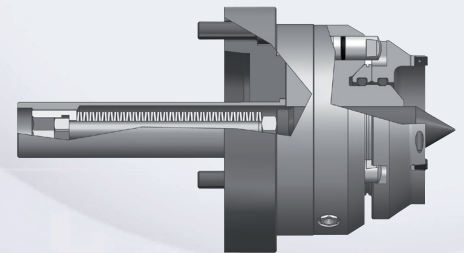

CoB

For the clamping of big and heavy workpieces. Also for extremely uneven faces. Basic body with morse taper or adaptor flange with disk spring package. Different driver heads with interchangeable driver pins and hydraulic compensation system. Rigid and axial adjustable spring loaded centres.
Max. workpiece weight: 500 kg
With intensified disk spring package: 1000 kg

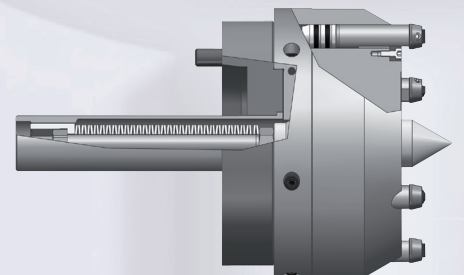

CoK

Our power operated Constant face driver CoK will be found in product group steady rests page 6335

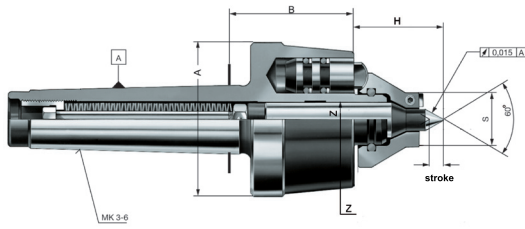

For rational turning of workpieces on their entire length without reclamping with high precision.

Developed according to the modular system, therefore universal exchange of driving discs and centres possible. One set consists of one basic body, one driving disc and suitable centre.

Technical features:

- hydraulic pressure compensation provides a uniform clamping force also on uneven faces of workpieces
- the spring loaded centre provides a longitudinal workpiece stop on the front side
- workpiece weight max. 100 kg
- approx. value for an axially admitted total load of the 3 supporting pistons: 2000 daN

Tool group A14
Type 680-50 **Basic body** with **morse taper** (all basic bodies without centre) CoA **hydraulic**

| Item no. | MT | A | B | H | Z | Stroke Centres | Weight approx. g |
|----------|----|----|------|-----------------|----|----------------|------------------|
| 088173 ● | 3 | 70 | 54 | max. 45 min. 26 | 16 | 10 | 1600 |
| 088174 ● | 4 | 70 | 56,5 | max. 45 min. 26 | 16 | 15 | 1800 |
| 088175 ● | 5 | 70 | 56,5 | max. 45 min. 26 | 16 | 15 | 2800 |
| 088176 ■ | 6 | 70 | 56,5 | max. 45 min. 26 | 16 | 15 | 4400 |

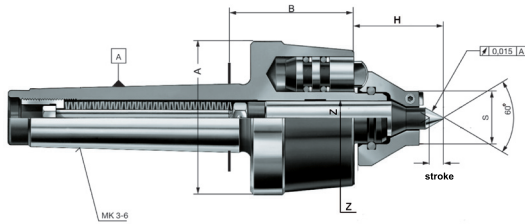

For rational turning of workpieces on their entire length without reclamping with high precision.

Developed according to the modular system, therefore universal exchange of driving discs and centres possible. One set consists of one basic body, one driving disc and suitable centre.

Technical features:

- hydraulic pressure compensation provides a uniform clamping force also on uneven faces of workpieces
- the spring loaded centre provides a longitudinal workpiece stop on the front side
- workpiece weight max. 100 kg
- approx. value for an axially admitted total load of the 3 supporting pistons: 2000 daN

Tool group A14
Type 680-55 **Basic body** with **morse taper**, with **draw-off nut**, CoA **hydraulic**

| Item no. | MT | A | B | H | Z | Stroke Centres | Weight approx. g |
|----------|----|----|------|-----------------|----|----------------|------------------|
| 088177 ■ | 3 | 70 | 54 | max. 45 min. 26 | 16 | 10 | 1800 |
| 088178 ● | 4 | 70 | 56,5 | max. 45 min. 26 | 16 | 15 | 2200 |
| 088179 ● | 5 | 70 | 56,5 | max. 45 min. 26 | 16 | 15 | 3000 |
| 088180 ● | 6 | 70 | 56,5 | max. 45 min. 26 | 16 | 15 | 4600 |

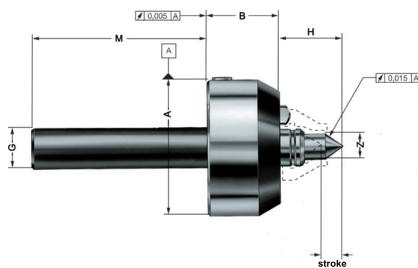

For rational turning of workpieces on their entire length without reclamping with high precision.

For clamping in lathe chucks with unstepped jaws. Developed according to the modular system, therefore universal exchange of driving discs and centres possible. One set consists of one basic body, one driving disc and suitable centre.

Technical features:

- hydraulic or mechanical pressure compensation provides a uniform clamping force also on uneven faces of workpieces
- the spring loaded centre provides a longitudinal workpiece stop on the front side
- workpiece weight max. 100 kg

Tool group A14
Type 680-65 **Basic body** for clamping in lathe chucks, with **spring set**, CoA **mechanical / hydraulic**

| Item no. | A | B | G | H | M | Z | Stroke Centres | Weight approx. g |
|------------------------|----|----|----|-----------------|-----|----|----------------|------------------|
| 088074 ¹⁾ ● | 85 | 45 | 25 | max. 45 min. 26 | 110 | 16 | 15 | 2300 |
| 313085 ²⁾ ■ | 85 | 45 | 25 | max. 45 min. 26 | 110 | 16 | 15 | 2300 |

¹⁾ with hydraulic compensation
²⁾ with mechanical compensation

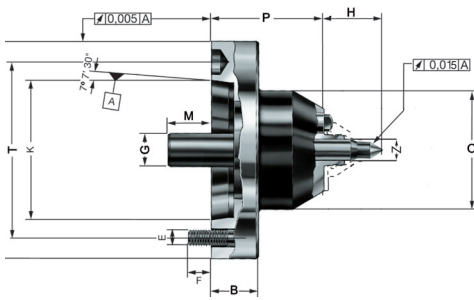

For rational turning of workpieces on their entire length without reclamping with high precision.

Developed according to the modular system, therefore universal exchange of driving discs and centres possible. One set consists of one basic body, one driving disc and suitable centre.

Technical features:

- mechanic pressure compensation provides a uniform clamping force also on uneven faces of workpieces
- the spring loaded centre provides a longitudinal workpiece stop on the front side
- workpiece weight max. 100 kg

Tool group A14
Type 681-85
Basic body with short taper ISO 702-1 (DIN 55026) mechanical compensation, with spring set, CoA mechanical

| Item no. | Taper | A | B | E | F | G | H | K | M | O | P | T | Z | Stroke Centres | Weight approx. g |
|--|-------|-----|----|------|----|----|-----------------|---------|----|----|----|-------|----|----------------|------------------|
| 313905 ■ | 5 | 133 | - | M 10 | 15 | 25 | max. 45 min. 26 | 82,563 | 32 | 90 | 86 | 104,8 | 16 | 11 | 6500 |
| 313906 ● | 6 | 165 | 35 | M 12 | 18 | 25 | max. 45 min. 26 | 106,375 | 32 | 90 | 86 | 133,4 | 16 | 11 | 7000 |
| 313907 ■ | 8 | 210 | 40 | M 16 | 23 | 25 | max. 45 min. 26 | 139,719 | 32 | 90 | 86 | 171,4 | 16 | 11 | 8100 |

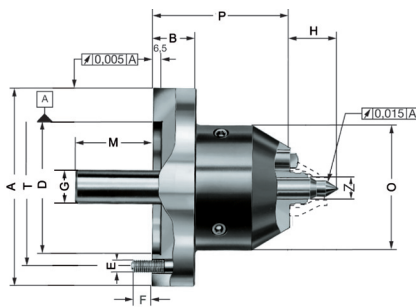

For rational turning of workpieces on their entire length without reclamping with high precision.

Developed according to the modular system, therefore universal exchange of driving discs and centres possible. One set consists of one basic body, one driving disc and suitable centre.

Technical features:

- hydraulic respectively mechanical pressure compensation provides a uniform clamping force also on uneven faces of workpieces
- the spring loaded centre provides a longitudinal workpiece stop on the front side
- workpiece weight max. 100 kg

Tool group A14
Type 680-60
Basic body flange type, with spring set, CoA mechanical / hydraulic

| Item no. | A | B | D | E | F | G | H | M | O | P | T | Z | Stroke Centres | Weight approx. g |
|--|-----|----|-----|------|----|----|-----------------|----|----|----|-----|----|----------------|------------------|
| 088046 ¹⁾ ● | 142 | 30 | 100 | M 10 | 15 | 25 | max. 45 min. 26 | 61 | 90 | 98 | 120 | 16 | 15 | 7300 |
| 313910 ²⁾ ■ | 142 | 30 | 100 | M 10 | 15 | 25 | max. 45 min. 26 | 61 | 90 | 98 | 120 | 16 | 15 | 7300 |

¹⁾ with hydraulic compensation
²⁾ with mechanical compensation

Adapter plate CoA

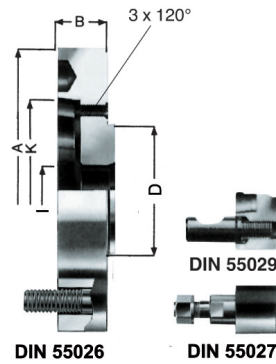

Tool group A14
Type 688-87
Adapter plate **short taper**
without spring set

| Item no. | Design | Taper | A | B | D | I | K | Weight approx. kg |
|----------|-----------|-------|-----|----|-----|----|---------|-------------------|
| 088485 ■ | DIN 55026 | 5 | 140 | 30 | 100 | 38 | 82,563 | 3,1 |
| 088486 ■ | DIN 55026 | 6 | 167 | 35 | 100 | 38 | 106,39 | 4,8 |
| 088487 ● | DIN 55026 | 8 | 216 | 40 | 100 | 38 | 139,735 | 8,7 |
| 088488 ■ | DIN 55026 | 11 | 280 | 45 | 100 | 38 | 196,885 | 17 |
| 088480 ▲ | DIN 55027 | 5 | 140 | 30 | 100 | 38 | 82,563 | 3,1 |
| 088481 ▲ | DIN 55027 | 6 | 167 | 35 | 100 | 38 | 106,39 | 4,8 |
| 088482 ▲ | DIN 55027 | 8 | 216 | 40 | 100 | 38 | 139,735 | 8,7 |
| 088483 ▲ | DIN 55027 | 11 | 280 | 45 | 100 | 38 | 196,885 | 17 |
| 088495 ▲ | DIN 55029 | 5 | 140 | 30 | 100 | 38 | 82,563 | 3,1 |
| 088496 ▲ | DIN 55029 | 6 | 167 | 35 | 100 | 38 | 106,39 | 4,8 |
| 088497 ▲ | DIN 55029 | 8 | 216 | 40 | 100 | 38 | 139,735 | 8,7 |
| 088498 ▲ | DIN 55029 | 11 | 280 | 45 | 100 | 38 | 196,885 | 17 |

Accessories CoA

Tool group A14
Type 680-10 **Driving discs**, toothed
right-hand rotation

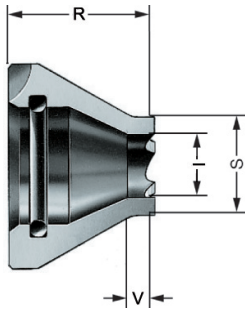

| Item no. | Clamping circuit $\varnothing S$ | Approx. turning range | I | R | V | Matching center point $\varnothing Y$ | Weight approx. g |
|----------|----------------------------------|-----------------------|-----|----|----|---------------------------------------|------------------|
| 088061 ● | 8 | 9-16 | 4,5 | 38 | 4 | 4 | 150 |
| 088062 ● | 10 | 11-20 | 4,5 | 38 | 4 | 4 | 180 |
| 088063 ● | 12 | 13-24 | 7 | 36 | 4 | 6 | 160 |
| 088064 ● | 16 | 17-32 | 11 | 33 | 4 | 10 | 160 |
| 088065 ● | 20 | 21-40 | 13 | 30 | 4 | 12 | 200 |
| 088066 ● | 25 | 26-50 | 17 | 30 | 8 | 16 | 170 |
| 088067 ● | 32 | 33-64 | 22 | 30 | 10 | 16 | 190 |

Driving discs with carbide toothing, friction lining or diamant granulation on request

Tool group A14
Type 680-20 **Driving discs**, toothed
left-hand rotation

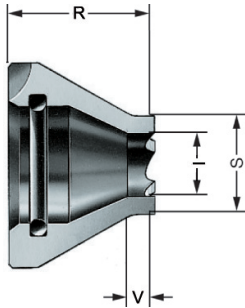

| Item no. | Clamping circuit $\varnothing S$ | Approx. turning range | I | R | V | Matching center point $\varnothing Y$ | Weight approx. g |
|----------|----------------------------------|-----------------------|-----|----|----|---------------------------------------|------------------|
| 088081 ● | 8 | 9-16 | 4,5 | 38 | 4 | 4 | 150 |
| 088082 ● | 10 | 11-20 | 4,5 | 38 | 4 | 4 | 180 |
| 088083 ● | 12 | 13-24 | 7 | 36 | 4 | 6 | 160 |
| 088084 ● | 16 | 17-32 | 11 | 33 | 4 | 10 | 160 |
| 088085 ● | 20 | 21-40 | 13 | 30 | 4 | 12 | 200 |
| 088086 ● | 25 | 26-50 | 17 | 30 | 8 | 16 | 170 |
| 088087 ● | 32 | 33-64 | 22 | 30 | 10 | 16 | 190 |

Driving discs with carbide toothing on request

Tool group A14
Type 680-30 **Driving discs**, toothed
right- and left-hand rotation

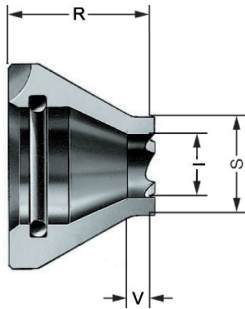

| Item no. | Clamping circuit $\varnothing S$ | Approx. turning range | I | R | V | Matching center point $\varnothing Y$ | Weight approx. g |
|----------|----------------------------------|-----------------------|-----|----|---|---------------------------------------|------------------|
| 088541 ● | 8 | 9-16 | 4,5 | 38 | 4 | 4 | 120 |
| 088542 ● | 10 | 11-20 | 4,5 | 38 | 4 | 4 | 120 |
| 088543 ● | 12 | 13-24 | 7 | 36 | 4 | 6 | 120 |
| 088544 ● | 16 | 17-32 | 11 | 33 | 4 | 10 | 120 |

Driving discs with carbide toothing on request

Tool group A14
Type 680-11 **Driving discs**, with interchangeable hard metal driving plates 6 x 3,2
right-hand rotation

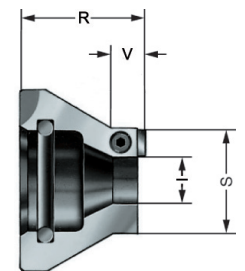

| Item no. | Clamping circuit $\varnothing S$ | Approx. turning range | I | R | V | Matching center point $\varnothing Y$ | Weight approx. g |
|----------|----------------------------------|-----------------------|------|----|----|---------------------------------------|------------------|
| 089065 ● | 20 H | 21-40 | 7 | 30 | 5 | 6 | 125 |
| 089066 ● | 25 H | 26-50 | 11 | 30 | 8 | 10 | 140 |
| 089067 ● | 32 H | 33-64 | 17,5 | 30 | 10 | 16 | 200 |

Accessories CoA

Tool group A14

Type 680-21 **Driving discs**, with interchangeable hard metal driving plates 6 x 3,2
left-hand rotation

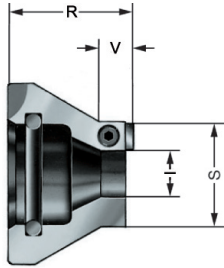

| Item no. | Clamping circuit Ø S | Approx. turning range | l | R | V | Matching center point ØY | Weight approx. g |
|----------|----------------------|-----------------------|------|----|----|--------------------------|------------------|
| 089085 ● | 20 H | 21-40 | 7 | 30 | 5 | 6 | 125 |
| 089086 ● | 25 H | 26-50 | 11 | 30 | 8 | 10 | 140 |
| 089087 ● | 32 H | 33-64 | 17,5 | 30 | 10 | 16 | 200 |

Tool group A14

Type 680-31 **Driving discs**, with interchangeable hard metal driving plates 6 x 3,2
right- and left-hand rotation

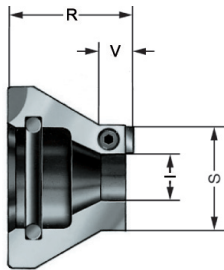

| Item no. | Clamping circuit Ø S | Approx. turning range | l | R | V | Matching center point ØY | Weight approx. g |
|----------|----------------------|-----------------------|------|----|----|--------------------------|------------------|
| 088545 ● | 20 H | 21-40 | 7 | 30 | 5 | 6 | 125 |
| 088546 ● | 25 H | 26-50 | 11 | 30 | 8 | 10 | 140 |
| 088547 ● | 32 H | 33-64 | 17,5 | 30 | 10 | 16 | 200 |

Tool group A14

Type 680-12 **Driving discs**, with interchangeable hard metal driving plates 6 x 3,2 which can be used on 4 sides
right-hand rotation

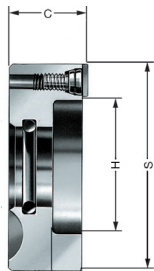

| Item no. | Clamping circuit Ø S | Approx. turning range | H | C | Matching center point ØY | Weight approx. g |
|----------|----------------------|-----------------------|----|----|--------------------------|------------------|
| 088068 ● | 40 | 41-80 | 20 | 24 | 16 | 600 |
| 088069 ● | 50 | 51-100 | 28 | 24 | 16 | 240 |
| 088070 ● | 63 | 64-126 | 41 | 24 | 16 | 400 |
| 088071 ● | 80 | 81-160 | 58 | 24 | 16 | 600 |

Tool group A14

Type 680-22 **Driving discs**, with interchangeable hard metal driving plates 6 x 3,2 which can be used on 4 sides
left-hand rotation

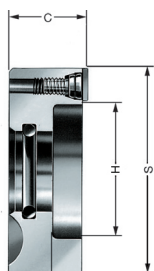

| Item no. | Clamping circuit Ø S | Approx. turning range | H | C | Matching center point ØY | Weight approx. g |
|----------|----------------------|-----------------------|----|----|--------------------------|------------------|
| 088088 ● | 40 | 41-80 | 20 | 24 | 16 | 600 |
| 088089 ● | 50 | 51-100 | 28 | 24 | 16 | 240 |
| 088090 ● | 63 | 64-126 | 41 | 24 | 16 | 400 |
| 088091 ● | 80 | 81-160 | 58 | 24 | 16 | 600 |

Accessories CoA

Tool group A14
Type 680-32 **Driving discs**, with interchangeable hard metal driving plates 6 x 3,2 which can be used on 4 sides right- **and** left-hand rotation

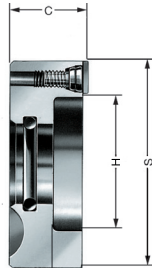

| Item no. | Clamping circuit Ø S | Approx. turning range | H | C | Matching center point ØY | Weight approx. g |
|----------|----------------------|-----------------------|----|----|--------------------------|------------------|
| 088548 ● | 40 | 41-80 | 20 | 24 | 16 | 600 |
| 088549 ● | 50 | 51-100 | 28 | 24 | 16 | 240 |
| 088550 ● | 63 | 64-126 | 41 | 24 | 16 | 400 |
| 088551 ● | 80 | 81-160 | 58 | 24 | 16 | 600 |

Tool group A14
Type 680-40 **Centres**, CoA

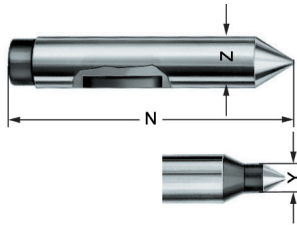

| Item no. | Clamping circuit Ø | N | Y | Z | Weight approx. g |
|----------|--------------------|-----|----|----|------------------|
| 088351 ● | 8-10 | 90 | 4 | 16 | 110 |
| 088352 ● | 12 | 90 | 6 | 16 | 110 |
| 088353 ● | 16 | 90 | 10 | 16 | 110 |
| 088354 ● | 20 | 90 | 12 | 16 | 110 |
| 088355 ● | 25-80 | 90 | 16 | 16 | 120 |
| 086758 ● | 25-80 | 110 | 16 | 16 | 150 |

Tool group A14
Type 680-45, **Centres with head**, CoA

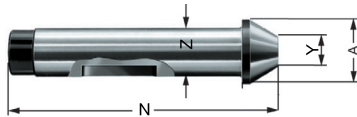

| Item no. | Taper Ø | | N | Z | Weight approx. g |
|----------|---------|----|----|----|------------------|
| | A | Y | | | |
| 086619 ● | 21 | 10 | 90 | 16 | 136 |
| 086620 ● | 27 | 16 | 90 | 16 | 153 |
| 688878 ● | 34 | 23 | 90 | 16 | 190 |
| 086621 ● | 40 | 29 | 90 | 16 | 210 |
| 688880 ● | 48 | 37 | 90 | 16 | 250 |
| 086622 ● | 56 | 45 | 90 | 16 | 312 |

Tool group A14
Type 680-90 **Hard metal driving plates**
right- **or** left-hand rotation



| Item no. | Size | Clamping circuit Ø | Weight approx. g |
|----------|---------|--------------------|------------------|
| 088810 ● | 6x3,2 | 20-32 | 2 |
| 088209 ● | 9,5x3,2 | 40-80 | 4 |

Tool group A14
Type 680-93 **Hard metal driving plates**
right- **and** left-hand rotation



| Item no. | Size | Clamping circuit Ø | Weight approx. g |
|----------|---------|--------------------|------------------|
| 088970 ● | 6x3,2 | 20-32 | 2 |
| 087931 ● | 9,5x3,2 | 40-80 | 4 |

Tool group A14
Type 680-72 **Mounting sleeve**
for the clamping of a face driver in lathe chuck

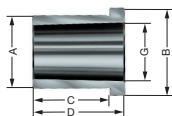

| Item no. | MT inside | A | B | C | D | G | Weight approx. g |
|----------|-----------|----|----|----|----|--------|------------------|
| 085033 ● | 3 | 31 | 39 | 32 | 40 | 23,825 | 150 |
| 085034 ● | 4 | 39 | 47 | 42 | 50 | 31,267 | 250 |
| 085035 ● | 5 | 54 | 62 | 52 | 60 | 44,399 | 480 |
| 085036 ● | 6 | 75 | 83 | 62 | 70 | 63,448 | 1050 |

Accessories CoA

Tool group C15
Type 0167-Y
Threaded pin



| Item no. | Size | Clamping circuit Ø | Weight approx. g |
|----------|---------|--------------------|------------------|
| 234695 ● | M 4 x 6 | 20 | 1 |
| 048205 ● | M 5 x 8 | 25+32 | 1 |
| 088205 ● | M 5 x 8 | 40-80 | 2 |

Tool group C15
Type 5191-Y
O-ring



| Item no. | Size |
|----------|------------|
| 006252 ● | 21,82x3,53 |

Tool group A14
Type 680
RÖHM slide rule to calculate axial tailstock loading



| Item no. | Weight approx. g |
|----------|------------------|
| 088230 ● | 35 |

CoA Assortments

Tool group A14
Type 680 **Basic equipment** in a carton
hydraulic, clamping dia. 12 + 32 mm, turning range 13-64 mm



| Item no. | MT | right-hand rotation | left-hand rotation | with draw-off nut | Weight approx. g |
|----------|----|---------------------|--------------------|-------------------|------------------|
| 088553 ● | 3 | • | | | 2100 |
| 088557 ■ | 3 | • | | • | 2400 |
| 088573 ■ | 3 | | • | | 2100 |
| 088577 ■ | 3 | | • | • | 2400 |
| 088554 ● | 4 | • | | | 2400 |
| 088558 ▲ | 4 | • | | • | 2700 |
| 088574 ▲ | 4 | | • | | 2400 |
| 088578 ▲ | 4 | | • | • | 2700 |
| 088555 ● | 5 | • | | | 3300 |
| 088559 ▲ | 5 | • | | • | 3600 |
| 088575 ▲ | 5 | | • | | 3300 |
| 088579 ▲ | 5 | | • | • | 3600 |
| 088556 ▲ | 6 | • | | | 4900 |
| 088560 ▲ | 6 | • | | • | 5200 |
| 088576 ▲ | 6 | | • | | 4900 |
| 088580 ▲ | 6 | | • | • | 5200 |

Tool group A14
Type 680 **Small assortment** in wooden box
hydraulic, clamping dia. 12-50 mm, turning range 13-100 mm



| Item no. | MT | right-hand rotation | left-hand rotation | with draw-off nut | Weight approx. g |
|----------|----|---------------------|--------------------|-------------------|------------------|
| 088501 ● | 3 | • | | | 3900 |
| 088511 ■ | 3 | • | | • | 4200 |
| 088521 ■ | 3 | | • | | 3900 |
| 088531 ▲ | 3 | | • | • | 4200 |
| 088502 ● | 4 | • | | | 4300 |
| 088512 ▲ | 4 | • | | • | 4600 |
| 088522 ■ | 4 | | • | | 4300 |
| 088532 ▲ | 4 | | • | • | 4600 |
| 088503 ● | 5 | • | | | 4900 |
| 088513 ▲ | 5 | • | | • | 5200 |
| 088523 ▲ | 5 | | • | | 4900 |
| 088533 ▲ | 5 | | • | • | 5200 |
| 088504 ● | 6 | • | | | 6600 |
| 088514 ▲ | 6 | • | | • | 6800 |
| 088524 ▲ | 6 | | • | | 6600 |
| 088534 ▲ | 6 | | • | • | 6800 |

Tool group A14
Type 680 **Large assortment** in wooden box
hydraulic, clamping dia. 10-80 mm, turning range 11-160 mm



| Item no. | MT | right-hand rotation | left-hand rotation | with draw-off nut | Weight approx. g |
|----------|----|---------------------|--------------------|-------------------|------------------|
| 088218 ■ | 3 | • | | | 5600 |
| 088223 ■ | 3 | | • | | 5600 |
| 088233 ■ | 3 | • | | • | 5900 |
| 088238 ■ | 3 | | • | • | 5900 |
| 088219 ▲ | 4 | • | | | 6000 |
| 088224 ▲ | 4 | | • | | 6000 |
| 088234 ● | 4 | • | | • | 6300 |
| 088239 ▲ | 4 | | • | • | 6300 |
| 088220 ▲ | 5 | • | | | 6600 |
| 088225 ▲ | 5 | | • | | 6600 |
| 088235 ▲ | 5 | • | | • | 6900 |
| 088240 ▲ | 5 | | • | • | 6900 |
| 088221 ▲ | 6 | • | | | 8300 |
| 088226 ▲ | 6 | | • | | 8300 |
| 088236 ▲ | 6 | • | | • | 8500 |
| 088241 ▲ | 6 | | • | • | 8500 |

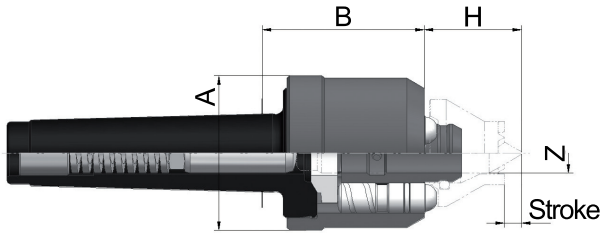

For rational turning of workpieces on their entire length without reclamping with high precision.

Developed according to the modular system, therefore universal exchange of driving discs and centres possible.
One set consists of one basic body, one driving disc and suitable centre.

Technical features:

- mechanic pressure compensation provides a uniform clamping force also on uneven faces of workpieces
- the spring loaded centre provides a longitudinal workpiece stop on the front side
- workpiece weight max. 100 kg
- Clamping circuit \varnothing 8-80 mm
- approx. value for an axially admitted total load of the 3 supporting pistons: 900 daN

Customer advantage:

- Face driver for turning and milling
- Compensating driving plates with radial freedom of movement
- Easy mechanical compensation of the driving plates
- Stable and consistent length stop
- High runout concentricity
- Easy to maintain

Tool group A14
Type 684-90

Basic body with morse taper
(all basic bodies without centre)
CoE

mechanical

| Item no. | MT | A | B | H | Z | Stroke | Centres | Weight approx. g |
|----------|----|----|----|-----------------|----|--------|---------|------------------|
| 310065 | 3 | 62 | 65 | max. 38 min. 26 | 16 | 10 | | 1800 |
| 310066 | 4 | 62 | 65 | max. 38 min. 26 | 16 | 10 | | 1900 |
| 310068 | 5 | 62 | 65 | max. 38 min. 26 | 16 | 10 | | 2000 |

Accessories CoE

Tool group A14

Type 684-30 **Driving discs, toothed**
right- and left-hand rotation, free from play

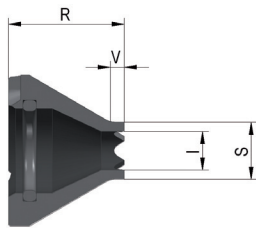

| Item no. | Clamping circuit \varnothing S | Approx. turning range | I | R | V | Matching center point \varnothing Y | Weight approx. g |
|----------|----------------------------------|-----------------------|-----|----|----|---------------------------------------|------------------|
| 1209000 | 8 | 9-16 | 4,5 | 38 | 4 | 4 | 120 |
| 1209001 | 10 | 11-20 | 4,5 | 38 | 4 | 4 | 120 |
| 1209002 | 12 | 13-24 | 7 | 36 | 4 | 6 | 120 |
| 1209003 | 16 | 17-32 | 11 | 33 | 4 | 10 | 120 |
| 1209004 | 20 | 21-40 | 13 | 30 | 4 | 12 | 120 |
| 1209005 | 25 | 26-50 | 17 | 30 | 8 | 16 | 130 |
| 1209006 | 32 | 33-64 | 22 | 30 | 10 | 16 | 160 |

Driving discs with carbide toothing on request

Tool group A14

Type 684-31 **Driving discs,**
with interchangeable hard metal driving plates 6 x 3,2
right- and left-hand rotation, free from play

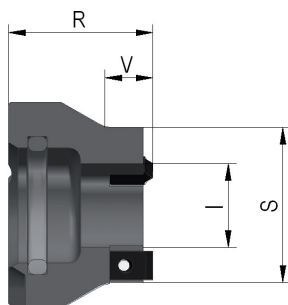

| Item no. | Clamping circuit \varnothing S | Approx. turning range | I | R | V | Matching center point \varnothing Y | Weight approx. g |
|----------|----------------------------------|-----------------------|------|----|----|---------------------------------------|------------------|
| 1209007 | 20 | 21-40 | 7 | 30 | 8 | 6 | 125 |
| 1209008 | 25 | 26-50 | 11 | 30 | 8 | 10 | 140 |
| 1209009 | 32 | 33-64 | 17,5 | 30 | 10 | 16 | 160 |
| 1209010 | 40 | 41-80 | 27 | 30 | 16 | 16 | 180 |

Accessories CoE

Tool group A14

Type 684-31 **Driving discs**, with interchangeable hard metal driving plates 6 x 3,2 which can be used on 4 sides right- and left-hand rotation, free from play

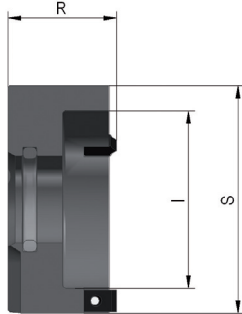

| Item no. | Clamping circuit Ø S | Approx. turning range | I | R | Matching center point ØY | Weight approx. g |
|---|----------------------|-----------------------|----|----|--------------------------|------------------|
| 1209011 ■ | 50 | 51-100 | 36 | 30 | 16 | 260 |
| 1209012 ■ | 63 | 64-126 | 49 | 30 | 16 | 420 |
| 1209013 ■ | 80 | 81-160 | 66 | 30 | 16 | 680 |

Tool group A14

Type 684-40 **Centres**, CoE

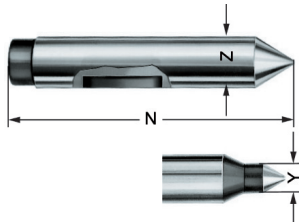

| Item no. | Clamping circuit Ø | N | Y | Z | Weight approx. g |
|---|--------------------|----|----|----|------------------|
| 1209016 ■ | 8-10 | 90 | 4 | 16 | 110 |
| 1209017 ■ | 12 | 90 | 16 | 6 | 110 |
| 1209018 ■ | 16 | 90 | 6 | 16 | 110 |
| 1209019 ■ | 20 | 90 | 12 | 16 | 110 |
| 1209020 ■ | 25-80 | 90 | 16 | 16 | 120 |

Tool group A14

Type 680-93 **Hard metal driving plates**

right- and left-hand rotation



| Item no. | Size | Clamping circuit Ø | Weight approx. g |
|---|-------|--------------------|------------------|
| 088970 ● | 6x3,2 | 20-32 | 2 |

Tool group A14

Type 680-72 **Mounting sleeve**

for the clamping of a face driver in lathe chuck

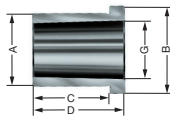

| Item no. | MT inside | A | B | C | D | G | Weight approx. g |
|---|-----------|----|----|----|----|--------|------------------|
| 085033 ● | 3 | 31 | 39 | 32 | 40 | 23,825 | 150 |
| 085034 ● | 4 | 39 | 47 | 42 | 50 | 31,267 | 250 |
| 085035 ● | 5 | 54 | 62 | 52 | 60 | 44,399 | 480 |

CoM

Constant face drivers CoM

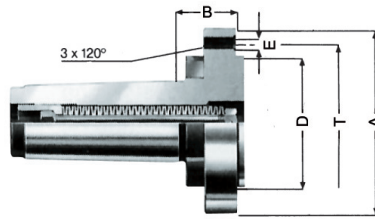

Tool group A14
Type 688
Basic body with morse taper and draw-off nut mechanical / hydraulic

| Item no. | MT | A | B | D | E | T | Weight approx. g |
|--|----|-----|----|-----|------|-----|------------------|
| 088295 ■ | 5 | 140 | 45 | 100 | M 10 | 120 | 5800 |
| 088296 ■ | 6 | 140 | 45 | 100 | M 10 | 120 | 7480 |

Adapter plate CoM

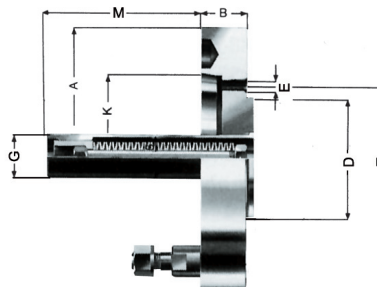

Tool group A14
Type 688
Adapter plate short taper with spring set

| Item no. | Taper | Design | A | B | D | E | G | K | M | T | Weight approx. g |
|--|-------|-----------|-----|----|-----|------|------|---------|-----|-----|------------------|
| 088331 ■ | 5 | DIN 55026 | 140 | 30 | 100 | M 10 | 37,5 | 82,563 | 144 | 120 | 4500 |
| 088332 ■ | 6 | DIN 55026 | 165 | 35 | 100 | M 10 | 37,5 | 106,39 | 139 | 120 | 7000 |
| 088333 ■ | 8 | DIN 55026 | 216 | 40 | 100 | M 10 | 37,5 | 139,735 | 134 | 120 | 11500 |
| 088334 ■ | 11 | DIN 55026 | 280 | 45 | 100 | M 10 | 37,5 | 196,885 | 129 | 120 | 23000 |
| 088335 ▲ | 5 | DIN 55027 | 140 | 30 | 100 | M 10 | 37,5 | 82,563 | 144 | 120 | 5500 |
| 088336 ▲ | 6 | DIN 55027 | 165 | 35 | 100 | M 10 | 37,5 | 106,39 | 139 | 120 | 7000 |
| 088337 ▲ | 8 | DIN 55027 | 216 | 40 | 100 | M 10 | 37,5 | 139,735 | 134 | 120 | 11500 |
| 088338 ▲ | 11 | DIN 55027 | 280 | 45 | 100 | M 10 | 37,5 | 196,885 | 129 | 120 | 23000 |
| 088339 ▲ | 5 | DIN 55029 | 140 | 30 | 100 | M 10 | 37,5 | 82,563 | 144 | 120 | 4500 |
| 088340 ▲ | 6 | DIN 55029 | 165 | 35 | 100 | M 10 | 37,5 | 106,39 | 139 | 120 | 7000 |
| 088341 ▲ | 8 | DIN 55029 | 216 | 40 | 100 | M 10 | 37,5 | 139,735 | 134 | 120 | 11500 |
| 088342 ▲ | 11 | DIN 55029 | 280 | 45 | 100 | M 10 | 37,5 | 196,885 | 129 | 120 | 23000 |

Driving head CoM

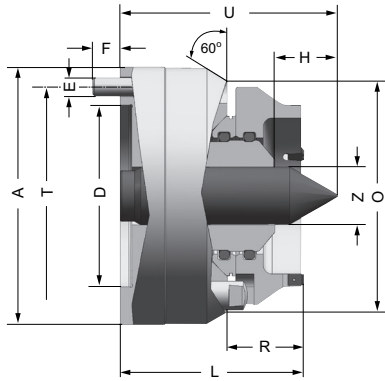

For clamping large and heavy workpieces, even with extremely uneven faces.

Technical features:

- spring loaded, rigid centre, axially adjustable
- basic body with morse taper or adapter plate with cup spring set
- workpiece weight max. 500 kg
- slip-on driving discs - clamping diameter 50-250 mm
- mechanical compensation

Tool group A14
Type 687
Face driving head
with cylindrical centre mount
mechanical

| Item no. | A | D | E | F | H | L | O | R | T | U | Z |
|----------|-----|-----|------|----|----|-----|-----|----|-----|-----|----|
| 689080 | 142 | 100 | M 10 | 15 | 35 | 102 | 128 | 38 | 120 | 120 | 32 |

Driving discs CoM

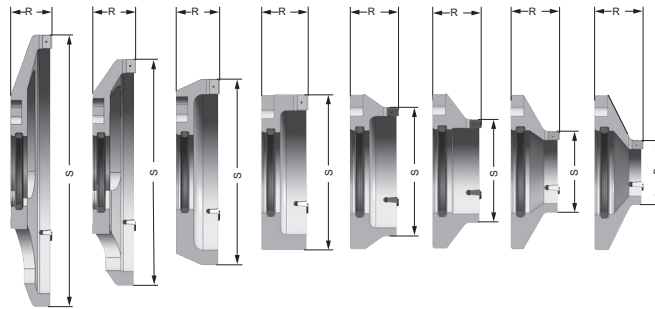

Tool group A14
Type 687-13
Driving discs
with interchangeable hard metal
driving plates
right-hand rotation

| Item no. | Clamping circuit Ø S | R | Hard metal driving plate | Weight approx. g |
|----------------------|----------------------|----|--------------------------|------------------|
| 689461 | 50 | 48 | 6 x 5T | 1400 |
| 689462 | 63 | 45 | 6 x 5T | 1500 |
| 689463 | 80 | 38 | 6 x 5T | 1500 |
| 689464 | 100 | 38 | 6 x 5T | 1400 |
| 689465 | 125 | 38 | 12 x 5T | 1800 |
| 689466 | 160 | 38 | 12 x 5T | 2500 |
| 689467 ¹⁾ | 200 | 38 | 12 x 5T | 2500 |
| 689468 ¹⁾ | 250 | 38 | 12 x 5T | 3200 |

¹⁾ Weight reduced

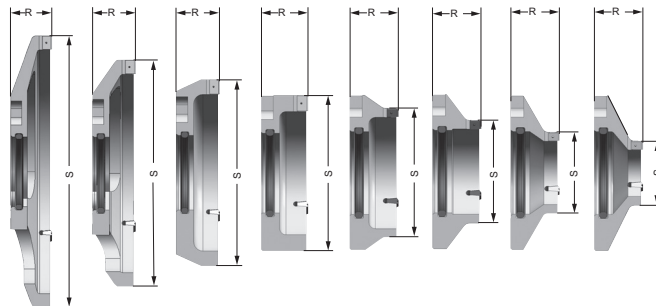

Tool group A14
Type 687-23
Driving discs
with interchangeable hard metal
driving plates
left-hand rotation

| Item no. | Clamping circuit Ø S | R | Hard metal driving plate | Weight approx. g |
|----------------------|----------------------|----|--------------------------|------------------|
| 689091 | 50 | 48 | 6 x 5T | 1400 |
| 689092 | 63 | 45 | 6 x 5T | 1500 |
| 689093 | 80 | 38 | 6 x 5T | 1500 |
| 689094 | 100 | 38 | 6 x 5T | 1400 |
| 689095 | 125 | 38 | 12 x 5T | 1800 |
| 689096 | 160 | 38 | 12 x 5T | 2500 |
| 689097 ¹⁾ | 200 | 38 | 12 x 5T | 2500 |
| 689098 ¹⁾ | 250 | 38 | 12 x 5T | 3200 |

¹⁾ Weight reduced

Accessories CoM

Tool group A14
Type 688-40 **Centres**

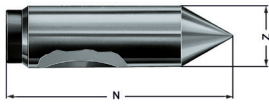

| Item no. | N | Z | Weight approx. g |
|----------|-----|----|------------------|
| 088292 ● | 120 | 32 | 620 |
| 088293 ● | 140 | 32 | 750 |

Tool group A14
Type 680-90 **Hard metal driving plates**
right- or left-hand rotation



| Item no. | Size | Weight approx. g |
|----------|----------|------------------|
| 312675 ● | 6 x 5 T | 3 |
| 312911 ● | 12 x 5 T | 6 |

Tool group C15
Type 0167-Y
Threaded pin



| Item no. | Size | Clamping circuit Ø | Weight approx. g |
|----------|----------|--------------------|------------------|
| 048205 ● | M 5 x 8 | 25+32 | 1 |
| 036461 ● | M 5 x 10 | | 1 |

Tool group C15
Type 5191-Y
O-ring



| Item no. | Size |
|----------|------------|
| 006283 ■ | 59,69x5,33 |

CoB

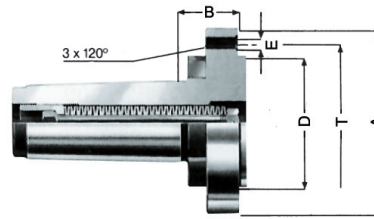

Tool group A14
Type 688

Basic body with morse taper
and draw-off nut
mechanical / hydraulic

| Item no. | MT | A | B | D | E | T | Weight approx. g |
|--|----|-----|----|-----|------|-----|------------------|
| 088295 ■ | 5 | 140 | 45 | 100 | M 10 | 120 | 5800 |
| 088296 ■ | 6 | 140 | 45 | 100 | M 10 | 120 | 7480 |

Adapter plate CoB

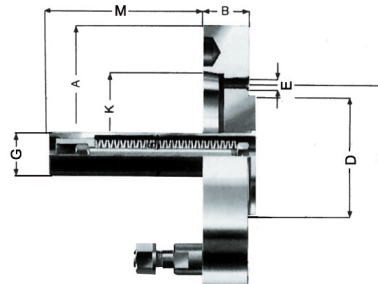

Tool group A14
Type 688 Adapter plate short
taper with spring set

| Item no. | Taper | Design | A | B | D | E | G | K | M | T | Weight approx. g |
|--|-------|-----------|-----|----|-----|------|------|---------|-----|-----|------------------|
| 088331 ■ | 5 | DIN 55026 | 140 | 30 | 100 | M 10 | 37,5 | 82,563 | 144 | 120 | 4500 |
| 088332 ■ | 6 | DIN 55026 | 165 | 35 | 100 | M 10 | 37,5 | 106,39 | 139 | 120 | 7000 |
| 088333 ■ | 8 | DIN 55026 | 216 | 40 | 100 | M 10 | 37,5 | 139,735 | 134 | 120 | 11500 |
| 088334 ■ | 11 | DIN 55026 | 280 | 45 | 100 | M 10 | 37,5 | 196,885 | 129 | 120 | 23000 |
| 088335 ▲ | 5 | DIN 55027 | 140 | 30 | 100 | M 10 | 37,5 | 82,563 | 144 | 120 | 5500 |
| 088336 ▲ | 6 | DIN 55027 | 165 | 35 | 100 | M 10 | 37,5 | 106,39 | 139 | 120 | 7000 |
| 088337 ▲ | 8 | DIN 55027 | 216 | 40 | 100 | M 10 | 37,5 | 139,735 | 134 | 120 | 11500 |
| 088338 ▲ | 11 | DIN 55027 | 280 | 45 | 100 | M 10 | 37,5 | 196,885 | 129 | 120 | 23000 |
| 088339 ▲ | 5 | DIN 55029 | 140 | 30 | 100 | M 10 | 37,5 | 82,563 | 144 | 120 | 4500 |
| 088340 ▲ | 6 | DIN 55029 | 165 | 35 | 100 | M 10 | 37,5 | 106,39 | 139 | 120 | 7000 |
| 088341 ▲ | 8 | DIN 55029 | 216 | 40 | 100 | M 10 | 37,5 | 139,735 | 134 | 120 | 11500 |
| 088342 ▲ | 11 | DIN 55029 | 280 | 45 | 100 | M 10 | 37,5 | 196,885 | 129 | 120 | 23000 |

Driving heads CoB

Constant face drivers CoB

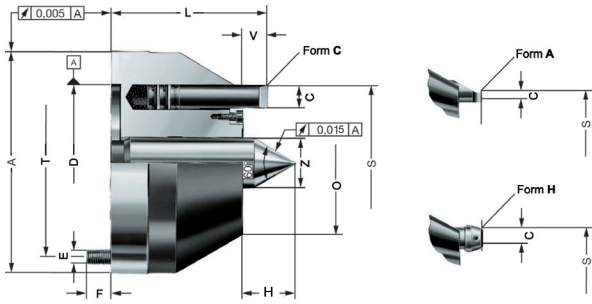

For clamping large and heavy workpieces, even with extremely uneven faces.

With hydraulic compensation - interchangeable driving pins
 Workpiece weight with single layer disk spring package: 500 kg
 Workpiece weight with double layer disk spring package: 1000 kg

Technical features:

- bolt-on face driver heads with interchangeable driving pins
- driving pins can be changed to allow right-hand or left-hand rotation
- spring loaded, rigid centre, axially adjustable

Tool group A14
 Type 688-10
 Face Driving Head **size 1** CoB;
hydraulic
right-hand rotation

| Item no. | S | Approx. turning range | A | C | D | E | F | H | L | O | T | V | Z | Pin | Weight approx. kg |
|----------|----|-----------------------|-----|------|-----|------|----|-----------------|-----|----|-----|----|----|----------|-------------------|
| 088301 | 63 | 65-125 | 142 | 6 | 100 | M 10 | 15 | max. 45 min. 18 | 102 | 72 | 120 | 16 | 25 | 6 x 16 A | 7 |
| 088361 | 75 | 80-150 | 142 | 9,5 | 100 | M 10 | 15 | max. 45 min. 18 | 102 | 72 | 120 | 16 | 25 | 6 x 16 H | 7 |
| 088302 | 80 | 82-160 | 142 | 14,5 | 100 | M 10 | 15 | max. 45 min. 18 | 102 | 72 | 120 | 16 | 25 | 6 x 16 C | 7 |

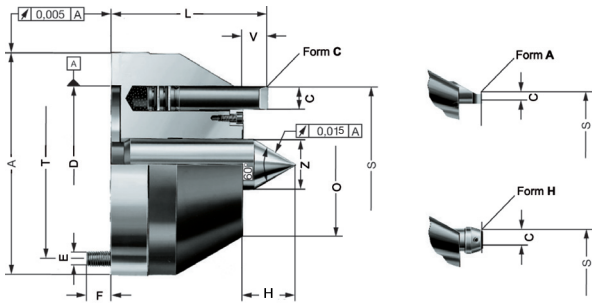

For clamping large and heavy workpieces, even with extremely uneven faces.

With hydraulic compensation - interchangeable driving pins
 Workpiece weight with single layer disk spring package: 500 kg
 Workpiece weight with double layer disk spring package: 1000 kg

Technical features:

- bolt-on face driver heads with interchangeable driving pins
- driving pins can be changed to allow right-hand or left-hand rotation
- spring loaded, rigid centre, axially adjustable

Tool group A14
 Type 688-10
 Face Driving Head **size 2** CoB;
hydraulic
right-hand rotation

| Item no. | S | Approx. turning range | A | C | D | E | F | H | L | O | T | V | Z | Pin | Weight approx. kg |
|----------|-----|-----------------------|-----|------|-----|------|----|-----------------|-----|----|-----|----|----|----------|-------------------|
| 088303 | 83 | 85-165 | 142 | 6 | 100 | M 10 | 15 | max. 45 min. 18 | 102 | 92 | 120 | 16 | 32 | 6 x 16 A | 8,2 |
| 088362 | 95 | 100-190 | 142 | 9,5 | 100 | M 10 | 15 | max. 45 min. 18 | 102 | 92 | 120 | 16 | 32 | 6 x 16 H | 8,2 |
| 088304 | 100 | 102-200 | 142 | 14,5 | 100 | M 10 | 15 | max. 45 min. 18 | 102 | 92 | 120 | 16 | 32 | 6 x 16 C | 8,2 |

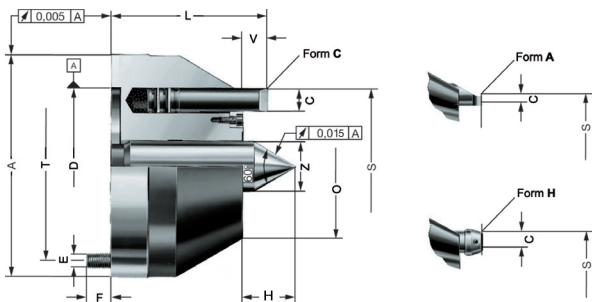

For clamping large and heavy workpieces, even with extremely uneven faces.

With hydraulic compensation - interchangeable driving pins
 Workpiece weight with single layer disk spring package: 500 kg
 Workpiece weight with double layer disk spring package: 1000 kg

Technical features:

- bolt-on face driver heads with interchangeable driving pins
- driving pins can be changed to allow right-hand or left-hand rotation
- spring loaded, rigid centre, axially adjustable

Tool group A14
 Type 688-10
 Face Driving Head **size 3** CoB;
hydraulic
right-hand rotation

| Item no. | S | Approx. turning range | A | C | D | E | F | H | L | O | T | V | Z | Pin | Weight approx. kg |
|----------|-----|-----------------------|-----|------|-----|------|----|-----------------|-----|-----|-----|----|----|----------|-------------------|
| 088305 | 108 | 110-215 | 142 | 6 | 100 | M 10 | 15 | max. 45 min. 18 | 102 | 117 | 120 | 16 | 32 | 6 x 16 A | 9,5 |
| 088363 | 120 | 125-240 | 142 | 9,5 | 100 | M 10 | 15 | max. 45 min. 18 | 102 | 117 | 120 | 16 | 32 | 6 x 16 H | 9,5 |
| 088306 | 125 | 127-250 | 142 | 14,5 | 100 | M 10 | 15 | max. 45 min. 18 | 102 | 117 | 120 | 16 | 32 | 6 x 16 C | 9,5 |

Driving heads CoB

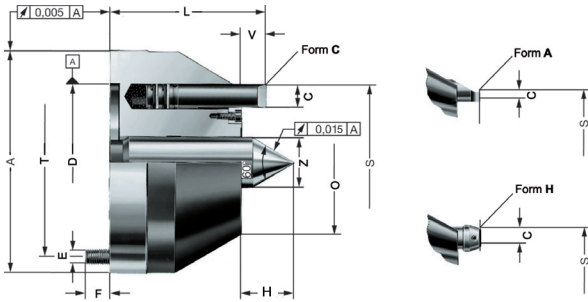

For clamping large and heavy workpieces, even with extremely uneven faces.

With hydraulic compensation - interchangeable driving pins
 Workpiece weight with single layer disk spring package: 500 kg
 Workpiece weight with double layer disk spring package: 1000 kg

Technical features:

- bolt-on face driver heads with interchangeable driving pins
- driving pins can be changed to allow right-hand or left-hand rotation
- spring loaded, rigid centre, axially adjustable

Tool group A14
 Type 688-10
 Face Driving Head size 4 CoB;
hydraulic
right-hand rotation

| Item no. | S | Approx. turning range | A | C | D | E | F | H | L | O | T | V | Z | Pin | Weight approx. kg |
|----------|-----|-----------------------|-----|------|-----|------|----|-----------------|-----|-----|-----|----|----|----------|-------------------|
| 088307 | 143 | 145-285 | 182 | 6 | 100 | M 10 | 15 | max. 45 min. 18 | 102 | 152 | 120 | 16 | 32 | 6 x 16 A | 16 |
| 088364 | 155 | 160-310 | 182 | 9,5 | 100 | M 10 | 15 | max. 45 min. 18 | 102 | 152 | 120 | 16 | 32 | 6 x 16 H | 16 |
| 088308 | 160 | 162-320 | 182 | 14,5 | 100 | M 10 | 15 | max. 45 min. 18 | 102 | 152 | 120 | 16 | 32 | 6 x 16 C | 16 |

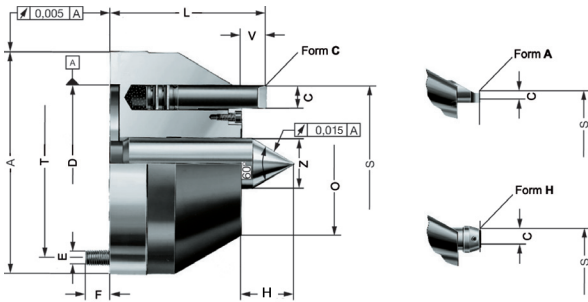

For clamping large and heavy workpieces, even with extremely uneven faces.

With hydraulic compensation - interchangeable driving pins
 Workpiece weight with single layer disk spring package: 500 kg
 Workpiece weight with double layer disk spring package: 1000 kg

Technical features:

- bolt-on face driver heads with interchangeable driving pins
- driving pins can be changed to allow right-hand or left-hand rotation
- spring loaded, rigid centre, axially adjustable

Tool group A14
 Type 688-20
 Face Driving Head size 1 CoB;
hydraulic
left-hand rotation

| Item no. | S | Approx. turning range | A | C | D | E | F | H | L | O | T | V | Z | Pin | Weight approx. kg |
|----------|----|-----------------------|-----|------|-----|------|----|-----------------|-----|----|-----|----|----|----------|-------------------|
| 088321 | 63 | 65-125 | 142 | 6 | 100 | M 10 | 15 | max. 45 min. 18 | 102 | 72 | 120 | 16 | 25 | 6 x 16 A | 7 |
| 088381 | 75 | 80-150 | 142 | 9,5 | 100 | M 10 | 15 | max. 45 min. 18 | 102 | 72 | 120 | 16 | 25 | 6 x 16 H | 7 |
| 088322 | 80 | 82-160 | 142 | 14,5 | 100 | M 10 | 15 | max. 45 min. 18 | 102 | 72 | 120 | 16 | 25 | 6 x 16 C | 7 |

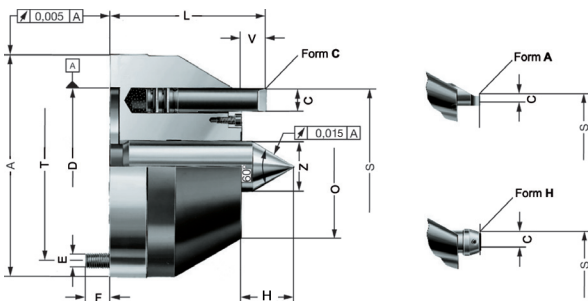

For clamping large and heavy workpieces, even with extremely uneven faces.

With hydraulic compensation - interchangeable driving pins
 Workpiece weight with single layer disk spring package: 500 kg
 Workpiece weight with double layer disk spring package: 1000 kg

Technical features:

- bolt-on face driver heads with interchangeable driving pins
- driving pins can be changed to allow right-hand or left-hand rotation
- spring loaded, rigid centre, axially adjustable

Tool group A14
 Type 688-20
 Face Driving Head size 2 CoB;
hydraulic
left-hand rotation

| Item no. | S | Approx. turning range | A | C | D | E | F | H | L | O | T | V | Z | Pin | Weight approx. kg |
|----------|-----|-----------------------|-----|------|-----|------|----|-----------------|-----|----|-----|----|----|----------|-------------------|
| 088323 | 83 | 85-165 | 142 | 6 | 100 | M 10 | 15 | max. 45 min. 18 | 102 | 92 | 120 | 16 | 32 | 6 x 16 A | 8,2 |
| 088382 | 95 | 100-190 | 142 | 9,5 | 100 | M 10 | 15 | max. 45 min. 18 | 102 | 92 | 120 | 16 | 32 | 6 x 16 H | 8,2 |
| 088324 | 100 | 102-200 | 142 | 14,5 | 100 | M 10 | 15 | max. 45 min. 18 | 102 | 92 | 120 | 16 | 32 | 6 x 16 C | 8,2 |

Driving heads CoB

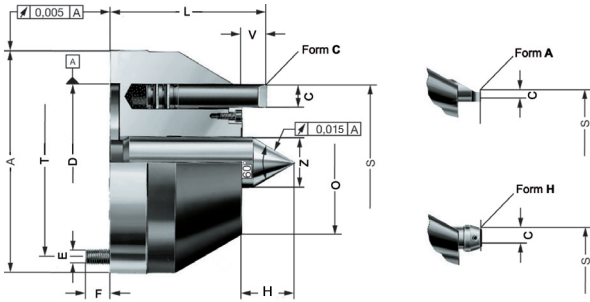

For clamping large and heavy workpieces, even with extremely uneven faces.

With hydraulic compensation - interchangeable driving pins
 Workpiece weight with single layer disk spring package: 500 kg
 Workpiece weight with double layer disk spring package: 1000 kg

Technical features:

- bolt-on face driver heads with interchangeable driving pins
- driving pins can be changed to allow right-hand or left-hand rotation
- spring loaded, rigid centre, axially adjustable

Constant face drivers CoB

Tool group A14
 Type 688-20
 Face Driving Head size 3 CoB;
hydraulic
left-hand rotation

| Item no. | S | Approx. turning range | A | C | D | E | F | H | L | O | T | V | Z | Pin | Weight approx. kg |
|----------|-----|-----------------------|-----|------|-----|------|----|-----------------|-----|-----|-----|----|----|----------|-------------------|
| 088325 | 108 | 110-215 | 142 | 6 | 100 | M 10 | 15 | max. 45 min. 18 | 102 | 117 | 120 | 16 | 32 | 6 x 16 A | 9,5 |
| 088383 | 120 | 125-240 | 142 | 9,5 | 100 | M 10 | 15 | max. 45 min. 18 | 102 | 117 | 120 | 16 | 32 | 6 x 16 H | 9,5 |
| 088326 | 125 | 127-250 | 142 | 14,5 | 100 | M 10 | 15 | max. 45 min. 18 | 102 | 117 | 120 | 16 | 32 | 6 x 16 C | 9,5 |

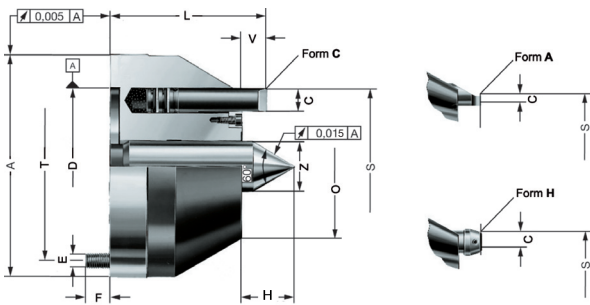

For clamping large and heavy workpieces, even with extremely uneven faces.

With hydraulic compensation - interchangeable driving pins
 Workpiece weight with single layer disk spring package: 500 kg
 Workpiece weight with double layer disk spring package: 1000 kg

Technical features:

- bolt-on face driver heads with interchangeable driving pins
- driving pins can be changed to allow right-hand or left-hand rotation
- spring loaded, rigid centre, axially adjustable

Tool group A14
 Type 688-20
 Face Driving Head size 4 CoB;
hydraulic
left-hand rotation

| Item no. | S | Approx. turning range | A | C | D | E | F | H | L | O | T | V | Z | Pin | Weight approx. kg |
|----------|-----|-----------------------|-----|------|-----|------|----|-----------------|-----|-----|-----|----|----|----------|-------------------|
| 088327 | 143 | 145-285 | 182 | 6 | 100 | M 10 | 15 | max. 45 min. 18 | 102 | 152 | 120 | 16 | 32 | 6 x 16 A | 16 |
| 088384 | 155 | 160-310 | 182 | 9,5 | 100 | M 10 | 15 | max. 45 min. 18 | 102 | 152 | 120 | 16 | 32 | 6 x 16 H | 16 |
| 088328 | 160 | 162-320 | 182 | 14,5 | 100 | M 10 | 15 | max. 45 min. 18 | 102 | 152 | 120 | 16 | 32 | 6 x 16 C | 16 |

Accessories CoB

Tool group A14
Type 688-40 **Centres**

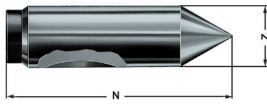

| Item no. | N | Z | Weight approx. g |
|----------|-----|----|------------------|
| 088291 ● | 120 | 25 | 390 |
| 088292 ● | 120 | 32 | 620 |
| 088293 ● | 140 | 32 | 750 |

Tool group C15
Type 689-91
driving pins, right-hand rotation

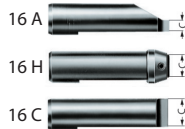

| Item no. | Diameter | Size | C | Length | Weight approx. g |
|----------|----------|------|------|--------|------------------|
| 085383 ● | 16 | 16 A | 6 | 60 | 80 |
| 088100 ● | 16 | 16 H | 9,5 | 60 | 90 |
| 085052 ● | 16 | 16 C | 14,5 | 60 | 85 |

Tool group C15
Type 689-92
driving pins, left-hand rotation

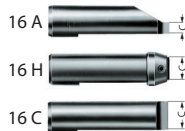

| Item no. | Diameter | Size | C | Length | Weight approx. g |
|----------|----------|------|------|--------|------------------|
| 085016 ● | 16 | 16 A | 6 | 60 | 80 |
| 088099 ● | 16 | 16 H | 9,5 | 60 | 90 |
| 085051 ● | 16 | 16 C | 14,5 | 60 | 85 |

Tool group A14
Type 680-90 **Hard metal driving plates**
right- or left-hand rotation



| Item no. | Size | Clamping circuit Ø | Weight approx. g |
|----------|---------|--------------------|------------------|
| 088209 ● | 9,5x3,2 | 40-80 | 4 |

Tool group A14
Type 688-89
Sleeve with spring set, suitable for adapter plates



| Item no. | Workpiece weight max. kg | Weight approx. g |
|----------|--------------------------|------------------|
| 086806 ■ | 500 | 800 |
| 087286 ■ | 1000 | 800 |



RÖHM GmbH

Heinrich-Röhm-Straße 50 | 89567 Sontheim/Brenz | Germany

Tel 0049 73 25 - 16-0 | Fax 0049 73 25 - 16-492

info@roehm.biz | www.roehm.biz